



transport

Department:
Transport
REPUBLIC OF SOUTH AFRICA

TRH 11

**DIMENSIONAL AND MASS LIMITATIONS
AND OTHER REQUIREMENTS FOR
ABNORMAL LOAD VEHICLES**

8th Edition

August 2009

ISBN 978-0-620-42786-9

Published in August 2009 by the
Department of Transport
Private Bag X193
PRETORIA
0001
REPUBLIC OF SOUTH AFRICA

Earlier Editions:

First Published in 1974
First revision in May 1979
Second revision March 1981
Reprinted in June 1982
Third revision April 1987
Fourth revision April 1992
Fifth revision November 1992
Sixth revision September 1997
Seventh revision March 2000

Printed in the
Republic of South Africa

FOREWORD

The history of TRH 11 dates back to 1970, when a committee, the Committee on Abnormal Loads, was formed comprising a team of traffic, road and structural engineers. This committee was tasked to develop recommendations for the adoption of a uniform approach to administer and govern the registration of abnormal vehicles and the conveyance of abnormal loads in South Africa. Throughout its history, the document they developed, generally known as TRH 11, remained under the care and development of this committee, now known as the Abnormal Loads Technical Committee. The document has been updated on a number of occasions on a needs basis to accommodate developments and trends in the transportation industry and a stage was reached where there was general consensus that the document needed a major revision. This latest version is the result of this major revision.

The objectives that were set for this latest revision of TRH 11 included the review of various requirements and technical provisions and the simplification and clarification of the document through the elimination of contradictions, ambiguities and duplications. In this latest revision, the technical issues and the administrative issues have been rightfully separated. The TRH 11 now focuses on technical issues, while a separate document, the Administrative Guidelines for Granting of Exemption Permits for the Conveyance of Abnormal Loads, has been developed. This latter document outlines the detailed procedures to follow when applying to register and operate abnormal vehicles and includes the rules or conditions which apply to the transporting of abnormal loads.

This latest revision process included comprehensive interaction with industry stakeholders (consignees, consignors, hauliers, manufacturers, industry associations and interested stakeholders/parties); as well as road and traffic authorities and I want to thank all those individuals and organizations for their participation and for the valuable input given.

Now that these guidelines have been revised, I appeal to all officials involved with the registering of abnormal vehicles and the issuing of exemption permits to apply these guidelines in a uniform way and to consult and interact with their counterparts in other provinces in order to achieve this

It was a great privilege to have worked with the team that developed this current version of TRH11 - Dimensional and Mass Limitations and Other Requirements for Abnormal Loads and the Administrative Guidelines for Granting of Exemption Permits for the Conveyance of Abnormal Loads.

Prasanth Mohan
Chairman: Abnormal Load Technical Committee
Deputy Manager: Overload Control
Department of Transport

SYNOPSIS

The National Road Traffic Act (Act 93 of 1996) and the National Road Traffic Regulations, 2000 prescribe certain limitations on vehicle dimensions and axle and vehicle masses that a vehicle using a public road must comply with. However, certain vehicles and loads cannot be moved on public roads without exceeding the limitations in terms of the dimensions and/or mass as prescribed. Where such a vehicle or load cannot be dismantled, without disproportionate effort, expense or risk of damage, into units that can travel or be transported legally, it is classified as an abnormal load and is allowed to travel on public roads under an exemption permit issued in terms of Section 81 of the National Road Traffic Act.

In this document various types of abnormalities and abnormal load and vehicle configurations are described. Abnormal load classification in terms of dimensions and mass is presented and routes are categorised in terms of paved width and posted speed limit. Dimensional and mass limitations for abnormal vehicles allowable under an exemption permit are defined. Marking and escorting requirements and speed restrictions applicable to abnormal vehicles are described. An overview of methods to estimate road pavement damage by abnormal vehicles is given.

TABLE OF CONTENTS

1.	Introduction.....	1-1
1.1	Background.....	1-1
1.2	Types of Abnormalities	1-2
1.2.1	Dimension Abnormality.....	1-2
1.2.2	Mass Abnormality	1-2
1.3	Load and Vehicle Configurations.....	1-2
1.4	Multiple Indivisible items in One Abnormal Load.....	1-4
1.5	Abnormal Load Classification	1-5
1.5.1	Background.....	1-5
1.5.2	Dimensional Classification.....	1-5
1.5.3	Mass Classification	1-5
1.6	Categories of Routes	1-5
1.6.1	Background.....	1-5
1.6.2	Route Classification	1-6
2.	Dimensional Limitations	2-1
2.1	Background.....	2-1
2.2	Length	2-1
2.2.1	Legally Permissible.....	2-1
2.2.2	Allowable under Permit.....	2-2
2.3	Width.....	2-2
2.3.1	Legally Permissible.....	2-2
2.3.2	Allowable under Permit.....	2-2
2.4	Height.....	2-3
2.4.1	Legally Permissible.....	2-3
2.4.2	Allowable under Permit.....	2-3
2.5	Overhangs.....	2-3
2.5.1	Front Overhang.....	2-4
2.5.2	Rear Overhang	2-4
2.6	Load Projections	2-5
2.6.1	Front Load Projection	2-5
2.6.2	Rear Load Projection	2-5
2.7	Wheelbase	2-6
2.7.1	Legally Permissible.....	2-6
2.7.2	Allowable under Permit.....	2-6
2.8	Turning Radius.....	2-6
2.8.1	Legally Permissible.....	2-6
2.8.2	Allowable under Permit.....	2-6

2.9	Stability.....	2-7
2.10	Ground Clearance	2-7
3.	Mass Limitations.....	3-1
3.1	Background.....	3-1
3.2	Loads on Tyres	3-1
3.2.1	Legally Permissible.....	3-1
3.2.2	Allowable under Permit.....	3-1
3.3	Manufacturer's Ratings	3-1
3.3.1	Legally Permissible.....	3-2
3.3.2	Allowable under Permit.....	3-2
3.4	Massload Carrying Capacity of Roads.....	3-2
3.4.1	Legally Permissible.....	3-2
3.4.2	Allowable under Permit.....	3-2
3.5	Massload Carrying Capacity of Bridges and Culverts	3-3
3.5.1	Legally Permissible.....	3-3
3.5.2	Allowable under Permit.....	3-3
3.5.3	Distances between Axle Groups	3-4
3.5.4	Tracking Requirements.....	3-4
3.6	Limitations Imposed by Drawing Vehicles (Power to Mass Ratio)	3-6
3.6.1	Legally Permissible.....	3-6
3.6.2	Allowable under Permit.....	3-6
3.7	Massload on Drive Axles (Traction Ratio)	3-6
3.7.1	Legally Permissible.....	3-7
3.7.2	Allowable under Permit.....	3-7
3.8	Massload on Steering Axles (Steering Ratio)	3-7
3.8.1	Legally Permissible.....	3-7
3.8.2	Allowable under Permit.....	3-7
4.	Marking and Escorting.....	4-1
4.1	Introduction	4-1
4.2	Description of Warning Apparatus	4-1
4.2.1	Flags	4-1
4.2.2	Boards.....	4-1
4.2.3	Lights	4-2
4.3	Warning Apparatus Requirements.....	4-3
4.3.1	Long and Wide Loads.....	4-3
4.3.2	Projections	4-3
4.3.3	Night Travel.....	4-3
4.3.4	Speed Restrictions.....	4-3
4.3.5	Warning Apparatus Prohibited.....	4-3

4.4	Escorting of Abnormal Vehicles	4-4
4.4.1	Background.....	4-4
4.4.2	Escort Classes.....	4-4
4.4.3	Escort Requirements	4-4
5.	Speed Restrictions	5-1
5.1	Background.....	5-1
5.2	Tyre Loading	5-1
5.3	Bridge Loading.....	5-1
5.4	Dimensions	5-2
5.5	Mobile Cranes.....	5-2
6.	Estimation of Relative Road Pavement Damage by Abnormal Vehicles.....	6-1
6.1	Introduction	6-1
6.2	Equivalent Single Wheel Mass (ESWM) Method.....	6-1
6.3	South African Mechanistic-empirical Pavement Design Methodology (SAMDM)	6-1
7.	Technical Detail and Calculations.....	7-1
7.1	Introduction	7-1
7.2	Detailed Glossary.....	7-1
7.2.1	5 th Wheel.....	7-1
7.2.2	Axle Configurations.....	7-1
7.2.3	Legal Axle Loads	7-2
7.3	Road Usage Factor (RUF) Calculation	7-2
7.4	Effective Width Calculation	7-2
7.4.1	Effective Width of a Single Axle or Single Axle Group	7-2
7.4.2	Weighted Effective Width Calculation.....	7-3
7.5	Tyre Pressure Calculation.....	7-4
8.	References	8-1

APPENDICES

Appendix A: Regulations applicable to Abnormal Loads and Vehicles.....	1
--	---

LIST OF TABLES

Table 1.1:	Classification According to Dimensions	1-5
Table 1.2:	Classification According to Mass	1-5
Table 1.3:	Route Classification	1-6
Table 2.1:	Maximum Overall Legal Dimensions (GVM/GCM exceeds 12 t).....	2-1
Table 2.2:	Maximum Overall Legal Length (including load projections)	2-1
Table 2.3:	Maximum Overall Length per Vehicle Type (including load projections).....	2-2
Table 2.4:	Actions Required when Transporting High Loads	2-3
Table 2.5:	Allowable Front/Rear Overhang under Permit.....	2-4
Table 2.6:	Allowable Rear Load Projections	2-5
Table 2.7:	Triggering Values for Stability Checks.....	2-7
Table 3.1:	Limitations on the Maximum Allowable Load (in kg) on Multi Axle Groups imposed by Bridges and Culverts.....	3-5
Table 4.1:	Warning Apparatus Requirements for Long and Wide Loads	4-3
Table 4.2:	Escort Requirements for Wide and Long Loads in terms of Dimension Class and Route Category.....	4-4
Table 4.3:	Escort Requirements for Wide and Long Loads in terms of the RUF.....	4-5
Table 5.1:	Speed Restrictions due to Tyre Loading.....	5-1
Table 5.2:	Maximum Allowable Speeds over Bridges	5-1
Table 5.3:	Maximum Allowable Speeds for Vehicles or Loads of Abnormal Dimensions	5-2
Table 5.4:	Maximum Allowable Speeds for Mobile Cranes	5-2
Table 7-1:	Examples of RUF Calculations	7-2
Table 7.2:	Variation in Load Capacity with Speed*	7-5
Table 7.3:	Example of a Load at Pressure Table	7-6

LIST OF FIGURES

Figure 1.1:	Abnormal Load on a Legal Combination	1-3
Figure 1.2:	Abnormal Load on a Long Wheelbase Trailer	1-3
Figure 1.3:	Self-Supporting Load on a Steerable Dolly.....	1-3
Figure 1.4:	Heavy Loads on Multi-axle or Modular Trailers	1-3
Figure 1.5:	Abnormally Heavy Mobile Cranes.....	1-3
Figure 1.6:	Multiple Indivisible Items in One Abnormal Load.....	1-4
Figure 2.1:	Front and Rear Overhangs	2-3
Figure 2.2:	Load Projections	2-5
Figure 2.3:	Illustration of Turning Radius	2-6
Figure 3.1:	Maximum Legal Loads on Axles and Axle Groups	3-2
Figure 3.2:	Distances between Axle Groups.....	3-4
Figure 4.1:	Abnormal Vehicle Warning Board.....	4-1

Figure 4.2: Escort Vehicle Warning Board 4-2
Figure 4.3: Speed Restriction Board 4-2
Figure 4.4: Warning Apparatus and Escort Requirements 4-7
Figure 7.1: 5th Wheel on Truck Tractor 7-1
Figure 7.2: Common Axle Configurations on Abnormal Vehicles 7-1
Figure 7.3: Legal Axle Loads in terms of Regulation 240 of the NRTR 7-2
Figure 7.4: Illustration of Effective Width Calculation..... 7-3
Figure 7.5: Example of ‘Weighted’ Effective Width Calculation 7-3
Figure 7.6: 4-Axle unit with 4-Duals in-line..... 7-5

DEFINITIONS

<i>Term</i>	<i>Definition</i>	<i>See also</i>
Abnormal load	An indivisible (for practical purposes) object that, due to its dimensions and/or mass, cannot be transported on a vehicle or vehicles without exceeding the limitations of the dimensions or mass as described in the National Road Traffic Regulations, 2000.	1.1
Abnormal vehicle	A vehicle or a combination of vehicles that, by virtue of its dimensions or mass, or a combination of both, does not comply with the requirements of the National Road Traffic Regulations, 2000. In Regulation 284 of the NRTR an abnormal vehicle is defined as: "Any vehicle which is operated under a written exemption granted in terms of section 81 of the Act and any motor vehicle accompanying such abnormal vehicle as a condition for operation."	1.1
Adapter dolly <i>(from NRTR)</i>	A semi-trailer with one or more axles, designed or adapted – (a) to be attached between a truck –tractor and semi-trailer, and (b) not to carry any load other than that imposed by a semi-trailer.	
Administrative Officer	A person appointed by the carrier and who, as far as the abnormal load or vehicle is concerned, is responsible for the conduct and operations of the carrier to whom a permit has been granted.	
Allowable	The maximum mass and dimensions, which the provincial authorities will allow in terms of the Guidelines. "Allowed" shall have a corresponding meaning.	
Articulated motor vehicle <i>(from NRTA)</i>	A combination of motor vehicles consisting of a truck-tractor and a semi-trailer.	Table 2.1 Sketch
AVR Number	A reference number which has been allocated to a vehicle, or a combination of vehicles that has been entered in a Register of Abnormal Vehicles approved by the Provincial Authorities.	
Axle <i>(from NRTR)</i>	In relation to a vehicle, means a device or set of devices, whether continuous across the width of the vehicle or not, about which the wheels of the vehicle rotate and which is so placed that, when the vehicle is travelling straight ahead, the vertical centre-lines of such wheels would be in one vertical plane at right angles to the longitudinal centre-line of such vehicle.	
Bridge	Any structure designed to carry vehicular traffic and which spans a gap of more than 6 m. In terms of the NRTA, a bridge includes a culvert and a causeway.	
Carrier	In the context of this document, means a person who undertakes the conveyance of abnormal loads by road for reward or in the course of his industry, trade or business by means of a motor vehicle.	

Term	Definition	See also
Converter dolly (from NRTR)	A trailer which has one or more axles and, when used in combination with a semi-trailer, converts the semi-trailer into a trailer.	
Detail route	Turn by turn description of the intended route to be used for the conveyance of the abnormal load, with reference to street names and route numbers.	
Dolly	Any of the following: a) a steerable dolly; or b) a converter dolly; or c) an adapter dolly.	
Drawbar trailer	A trailer which is attached to a drawing vehicle by a drawbar.	
Driver	In addition to the definition contained in the NRTA, any person who controls or activates the steering mechanism of any steerable axle or axle unit of a trailer or semi-trailer.	
Dual tyre spacing	The distance from the centre of the tread of one tyre to the centre of the tread of the closest tyre similarly mounted on an axle.	7.2.2
Dual wheel	Two tyres, mounted on separate rims, rigidly attached to each other on an axle.	7.2.2
Effective width	The dimension used in calculating loads on bridges, and is determined by adding 1,2 m to the width of a vehicle measured to the outside of the tyres. If the distance between adjacent tyres exceeds 1,2 m, such excess must be deducted from the effective width.	7.4 Effective Width Calculation
Escort	A person in a separate escort vehicle accompanying an abnormal load/vehicle for the purpose of assisting other road users and giving timely warning of the presence of an abnormal load/vehicle.	4.4 Escorting
Equivalent single wheel mass (ESWM)	The isolated single-wheel load which, operating at 520 kPa cold tyre pressure would produce the same effect in a particular road pavement as that produced by all the wheels in that group.	6-1
Extendable semi-trailer	A semi-trailer constructed with a telescopic chassis to enable the overall length and wheelbase to be increased as required.	
Fifth wheel	A device fitted to a truck-tractor, adapter or converter dolly in order to permit articulation between the said unit and a semi-trailer.	7.2.1 5th Wheel

Term	Definition	See also
Front overhang <i>(from NRTR)</i>	In relation to a vehicle means that portion of the vehicle, excluding any drawbar or coupling, which projects in front of the centre-line of the front axle or the foremost axle of the front axle unit or, if such vehicle has only one axle, which projects in front of the centre-line of that axle, or in the case of a semi-trailer, which projects in front of the centre-line of the kingpin: Provided that any portion of a semi-trailer which projects in front of its front end or anything attached to a semi-trailer in front of its front end and which is within an area formed by drawing, with the king-pin as centre, an arc connecting the extreme points of the front end of the semi-trailer, shall not be deemed to be part of the front overhang of such semi-trailer.	2.5.1
Gross	There are several definitions in the NRTA and the NRTR which include the word "gross". In all cases the word "gross" refers to the manufacturer's rating, e.g. Gross Axle Massload (GA) refers to the maximum massload of the particular axle as specified by the motor vehicle manufacturer.	
Gross combination mass (GCM) <i>(from NRTA)</i>	In relation to a motor vehicle which is used to draw any other motor vehicle, means the maximum mass of any combination of motor vehicles, including the drawing vehicle, and load as specified by the manufacturer thereof or, in the absence of such specification, as determined by the registering authority.	
Gross vehicle mass (GVM) <i>(from NRTA)</i>	In relation to a motor vehicle, means the maximum mass of such vehicle and its load as specified by the manufacturer thereof or, in the absence of such specification, as determined by the registering authority.	
Guidelines	The Administrative Guidelines for Granting of Exemption Permits for the Conveyance of Abnormal Loads, developed by the Abnormal Loads Technical Committee, which derives its mandate from the Roads Co-ordination Body (RCB), which reports to the Committee of Transport Officials (COTO).	
Indivisible load	A load which cannot, without disproportionate effort, expense or risk of damage, be divided into two or more loads for the purpose of transport on public roads.	
Kingpin	The attaching pin on semi-trailer or adapter dolly which matches the fifth wheel on the truck-tractor, adapter or converter dolly, coupling the vehicles together.	
Laden mass	Laden mass includes the unladen mass and the payload.	
Load projection	This is the portion of the load that extends forward beyond the front end of the vehicle or rearward beyond the rear end of the vehicle.	
Mass	The quantity of matter which a body contains, irrespective of its bulk or volume. It is measured in kilograms in the SI system of measurement.	

Term	Definition	See also
MEC <i>(from NRTA)</i>	A member of the Executive Council appointed in terms of section 132 of the Constitution of the Republic of South Africa, 1996 (Act No. 108 of 1996), and who is responsible for road traffic matters, or any other person authorised by him or her to exercise any power or perform any duty or function which such MEC is empowered or obliged to exercise or perform in terms of this Act.	
Mobile crane	A self-propelled machine specially designed for lifting loads. Mobile cranes can be placed in the following three classes: 1. Centre mounted (rough terrain) mobile cranes; 2. Truck mounted mobile cranes; and 3. All terrain mobile cranes.	Figure 1.5 Figure 1.6 Figure 1.7
Modular trailer	A towed vehicle composed of inter-connectable and interchangeable modules. Modules can be different in size and can be coupled in a variety of combinations.	
Multi-axle trailer	A trailer with multiple axles either evenly distributed under the loading deck or in a front and rear group. The axles are steerable and the trailer is attached to the drawing vehicle by a towbar or a variable gooseneck.	
National Road Traffic Act (NRTA)	The National Road Traffic Act, 1996 (Act 93 of 1996), as amended.	
National Road Traffic Regulations (NRTR)	The National Road Traffic Regulations, 2000, as amended, made under Section 75 of the NRTA.	
Operator <i>(from NRTA)</i>	The person responsible for the use of a motor vehicle of any class contemplated in Chapter VI (of the NRTA), and who has been registered as the operator of such vehicle.	
Payload	The mass of those goods being carried by the vehicle or combination of vehicles, the transport of which from one place to another is the purpose for which the journey is being undertaken, and includes any special equipment required for securing a particular load.	
Permissible	The maximum dimensions and mass of vehicles or combination of vehicles permitted in terms of the NRTR.	
Permit	An exemption permit issued by a Provincial Roads Authority in terms of Section 81 of the NRTA, authorising the transportation of an abnormal load or the movement of an abnormal vehicle or a combination of vehicles subject to such terms and conditions and the payment of such fees as may be imposed.	

Term	Definition	See also
Person in charge	The person appointed by the carrier operating an abnormal vehicle or operating a vehicle carrying an abnormal load, to accompany such a vehicle or load in order to supervise operations and ensure compliance with the permit conditions. This person must assume full responsibility on behalf of the carrier while the vehicle is on the road.	
Power/mass ratio	The ratio between the net power of the engine(s) in the hauling vehicle(s) and the gross mass of the vehicle(s) or combination of vehicles.	3.6
Principle approval	Approval that is obtained by a manufacturer or importer of a vehicle (or load) prior to commitment to import or manufacture in order to obtain assurance that the vehicle (or load) would be granted exemptions to travel on a public road in future.	
Rear overhang (from NRTR)	In relation to a vehicle, means that portion of the vehicle which projects to the rear of the centre-line of the rear axle or the rearmost axle of the rear axle unit or, if such vehicle has only one axle, which projects to the rear of the centre-line of that axle.	2.5.2
Register of abnormal vehicles	A record of abnormal load vehicles, details of which have been submitted to, and which have been accepted by the Provincial Authorities as being suitable for the conveyance of abnormally heavy loads.	
Rigid vehicle	A single vehicle with two or more axles or groups of axles operating independently.	Table 2.1 Sketch
Road Usage Factor (RUF)	The Road Usage Factor is a factor calculated from the overall length and overall width of the vehicle to give an indication of the warning devices and escorts that are required when the vehicle travels on a public road.	7.3
Route Clearance	A statement by a registered professional engineer with structural as well as road safety and traffic engineering competencies, to the effect that the detail route provided was inspected by him/her and is safe for the transportation of the intended abnormal load. It must include the vehicle configuration and unit loading used in his/her calculations as well as a list of all structures along the route and when they were inspected. The engineer responsible for the route clearance carries the full risk with regard to claims and structural failures and as such must have adequate professional indemnity insurance to cover that risk.	
Self-supporting load	A load which, because of its design and construction, is used as part of the structure of the vehicle or combination of vehicles on which it is transported.	Figure 1.3
Semi-trailer (from NRTA)	A trailer having no front axle and so designed that at least 15 per cent of its tare is super-imposed on and borne by a vehicle drawing such trailer.	

Term	Definition	See also
Sequence number	A reference number which has been allocated to a single vehicle or to a component vehicle of a combination and which has been entered in the Register of Abnormal Vehicles by the Provincial Authorities.	
Stability check	Calculations performed by a registered professional engineer to determine the stability angle, safe travelling speed as well as safe wind speed in order to establish if an abnormal load may be safely carried on a particular vehicle. Centre of gravity of the vehicle, the load and the combined centre of gravity of the laden vehicle as well as all assumptions that the calculations were based upon, need to be shown.	
Steerable axle	An axle which may be steered either manually or automatically. A steerable axle group is steerable in the sense that it is capable of moving the vehicle laterally in a controlled manner.	
Steerable dolly	A trailer, with one or more axles (of which at least one must be steerable), designed or adapted generally or specifically for supporting the rear end of a self-supporting load and equipped with a turntable to enable it to pivot.	
Tag axle	A non-powered, independently-suspended axle in an axle unit.	
Tare (from NRTA)	In relation to a motor vehicle, means the mass of such vehicle ready to travel on a road and includes the mass of— a) any spare wheel and of all other accessories and equipment supplied by the manufacturer as standard for the particular model of motor vehicle concerned; b) anything which is a permanent part of the structure of such vehicle; c) anything attached to such vehicle so as to form a structural alteration of a permanent nature; and d) the accumulators, if such vehicle is self-propelled by electrical power, but does not include the mass of— i) fuel; and ii) anything attached to such vehicle which is not of the nature referred to in paragraph (b) or (c).	
Tracking over bridges	Travelling along a path over a bridge which minimizes overstressing of the structure.	3.5.4
Traffic officer	A traffic officer is defined in the Road Traffic Act, Act 29 of 1989 as follows: “Traffic officer means a traffic officer appointed under section 3 and any member of the Force as defined in section 1 of the Police Act, 1958 (Act no 7 of 1958) and for the purpose of Chapters IV, VI, VII and VIII and sections 131 and 135 of this Act includes a peace officer”.	
Truck-tractor (from NRTA)	A motor vehicle designed or adapted— a) for drawing other vehicles; and b) not to carry any load other than that imposed by a semi-trailer or by ballast, but does not include a tractor.	

Term	Definition	See also
Turning radius <i>(from NRTR)</i>	Turning radius in relation to a vehicle, means the radius of the circle described by the outer steered wheel of a vehicle when such wheel is deflected as far as possible from the straight, either to the left or to the right, and, where the radii so obtained are not the same, the larger of the two shall be taken as the turning radius of the vehicle, the radius being measured to the outer edge of the track described by such outer steered wheel.	2.8
Unladen mass	In relation to a vehicle or combination of vehicles, means the mass of such a vehicle or combination of vehicles when ready to travel on a road, and includes a) the tare; b) the mass of the fuel when the tanks are full; c) the mass of the driver and any other personnel carried; and d) the mass of any other accessories and equipment normally carried, but excludes the payload.	
Wheelbase <i>(from NRTR)</i>	a) in relation to a semi-trailer, means the distance measured at ground level, between parallel planes at right-angles to the longitudinal centre-line of the vehicle passing through the centre-line of its king-pin and the centre-line of its axle or axle unit, as the case may be; b) in relation to a trailer with only one axle or one axle unit, other than a semi-trailer, means the distance, measured at ground level, between parallel planes at right angles to the longitudinal centre-line of the vehicle passing through the centre-line of the coupling pin or knuckle and the centre-line of such axle or axle unit as the case may be; and c) in relation to any other vehicle, means the distance measured at ground level between parallel planes at right-angles to the longitudinal centre-line of the vehicle passing through the centre-line of the front axle or front axle unit and the centre-line of the rear axle or rear axle unit, as the case may be.	2.7
Wheeltrack	The measurement to the outside of the outer wheels of the load carrying axles of a vehicle.	

1. INTRODUCTION

1.1 Background

The National Road Traffic Act (Act 93 of 1996) (herein referred to as the NRTA) and the National Road Traffic Regulations, 2000 (herein after referred to as the NRTR), prescribe certain limitations on vehicle dimensions and axle and vehicle masses with which a vehicle using a public road must comply. However, certain vehicles and loads cannot be moved on public roads without exceeding the limitations in terms of the dimensions and/or mass as prescribed in the NRTR. Where such a vehicle or load cannot be dismantled without disproportionate effort, expense or risk of damage into units that can travel or be transported legally, it is classified as an abnormal load. Provision for such abnormal vehicles and loads is made in Section 81¹ of the NRTA, which reads as follows:

“Vehicle and load may be exempted from provisions of Act

81. (1) The Minister may, after the applicant has paid the fees or charges referred to in section 7(3) and subject to such conditions as he or she may determine, authorise in writing, either generally or specifically, the operation on a public road of a vehicle which, due to such vehicle’s original design cannot comply with this Act.

(2) The MEC may, after the applicant has paid the fees or charges referred to in section 7(3) and subject to such conditions as he or she may determine, authorise in writing, either generally or specifically, the conveyance in a safe manner on a public road of passengers or any load otherwise than in accordance with this Act.

(3) An MEC shall determine the fees or charges payable for a vehicle or load that does not comply with this Act.”

When the movement of an abnormal load is considered to be in the economic and/or social interest of the country, an exemption permit may be issued to allow a vehicle(s) transporting such an abnormal load to operate on a public road for a limited period.

Exemption permits are issued by provincial permit offices in terms of guidelines developed by the Abnormal Loads Technical Committee (ALTC).

Abnormal vehicles, whether in terms of dimensions and/or mass, operate outside the criteria used for the geometrical and structural design of road infrastructure. An abnormal vehicle operating on the road therefore creates additional risks in terms of damage to the road infrastructure and the safety of other road users. Road authorities have to assess these risks, put measures in place to minimize the identified risks and ensure that they are properly managed.

The purpose of this document is to assist road authorities and carriers to assess and minimize the risks created through the movement of abnormal vehicles on the road network.

The fundamental principles guiding this process are:

¹ As substituted by Section 23 of Act 64 of 2008: National Road Traffic Amendment Act, 2008.

- An exemption permit for an abnormal load will only be considered for an indivisible load, abnormal in dimension and/or mass, where there is no possibility of transporting the load in a legal manner;
- The damage to the road infrastructure by an abnormal vehicle has to be recovered from the carrier;
- The risks to other road users must be reduced to a level equivalent to a situation without the presence of the abnormal vehicle on the road; and
- The conditions imposed must take into account the economic and/or social interest of the country and public at large.
- The purpose of the exemption permit system is not to undermine or circumvent the NRTA and the NRTR.
- This document contains recommendations that are generally applicable, but the issuing authority can deviate from these recommendations and/or impose additional requirements when taking the circumstances applicable to each application into account.

1.2 Types of Abnormalities

A vehicle or a vehicle with its load that is considered to be indivisible, can be abnormal either in terms of dimension or mass or both.

1.2.1 Dimension Abnormality

A vehicle/combination is dimensionally abnormal when any of the following dimensions exceeds the legal limitations:

- Length
- Width
- Height
- Overhangs
- Load projections
- Wheelbase

Such dimensional abnormalities are described in Section 2.

1.2.2 Mass Abnormality

When the allowable mass of the vehicle/combination or one or more axle groups exceeds the legal limitations, a mass abnormality exists. This is discussed in Section 3.

1.3 Load and Vehicle Configurations

A number of typical abnormal load/vehicle configurations are illustrated in the following Figure 1.1 to Figure 1.7.

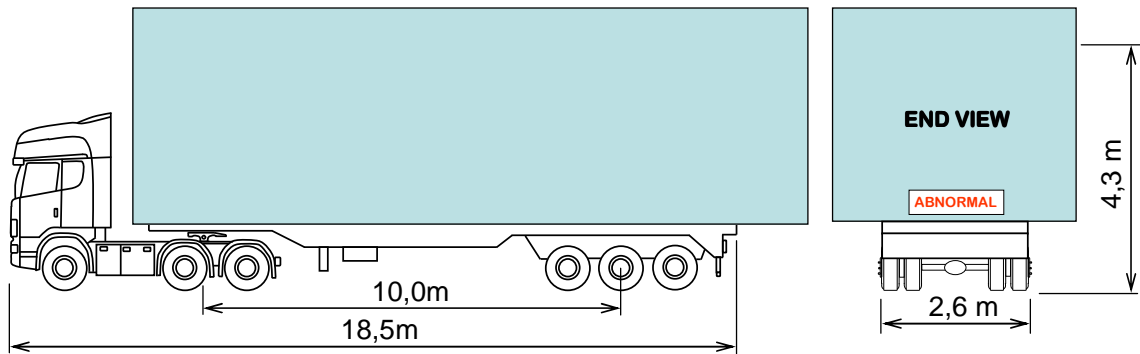

Figure 1.1: Abnormal Load on a Legal Combination

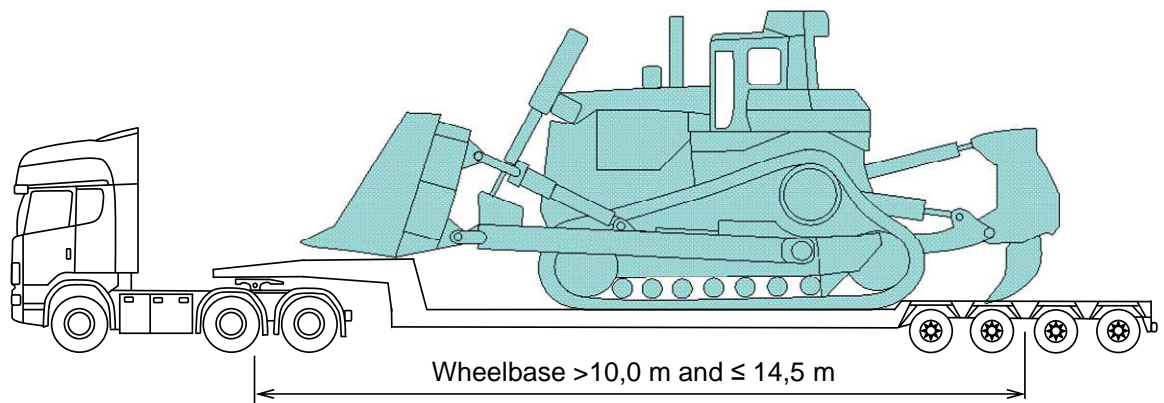

Figure 1.2: Abnormal Load on a Long Wheelbase Trailer

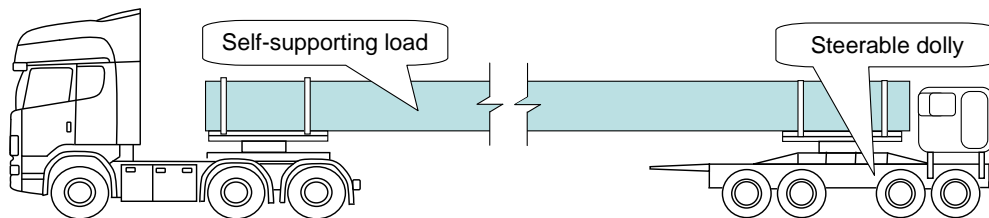

Figure 1.3: Self-Supporting Load on a Steerable Dolly

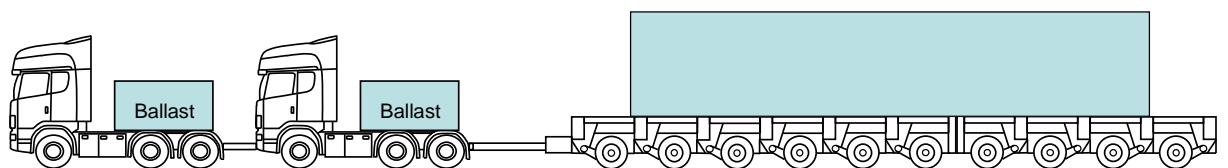

Figure 1.4: Heavy Loads on Multi-axle or Modular Trailers

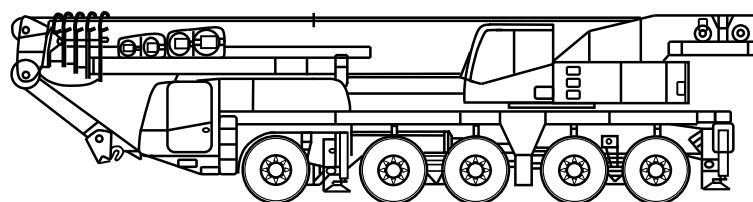

Figure 1.5: All Terrain Mobile Crane

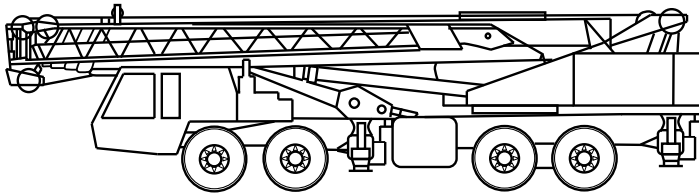

Figure 1.6: Truck Mounted Mobile Crane

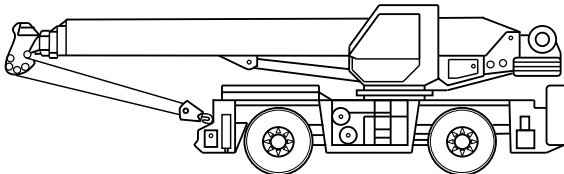

Figure 1.7: Centre Mounted (Rough Terrain) Mobile Crane

1.4 Multiple Indivisible Items in One Abnormal Load

In some cases authorities may allow the transportation of more than one indivisible item that is abnormal in one dimension as long as an additional abnormality in another dimension is not created and the total mass is within legal limits. In this manner, the number of abnormal vehicles (or abnormal load trips) on the road is reduced and therefore also the risk to other road users.

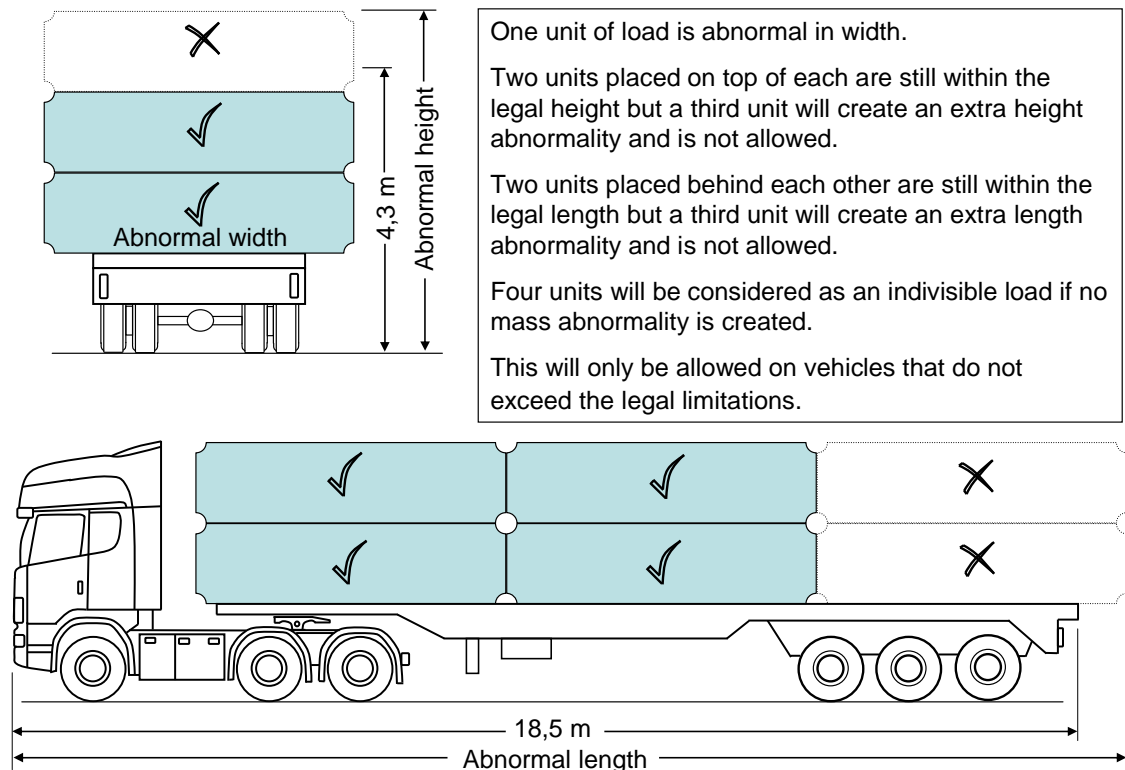

Figure 1.8: Multiple Indivisible Items in One Abnormal Load.

1.5 Abnormal Load Classification

1.5.1 Background

The conditions under which a permit is granted for an abnormal load become more stringent as the degree of abnormality increases. By dividing abnormal loads into classes according to overall dimensions and mass, the setting of permit conditions is facilitated.

1.5.2 Dimensional Classification

The dimensional classification is according to overall width and overall length. Both the width and the length must fall within the limits to belong to a certain class.

Table 1.1: Classification According to Dimensions

Class	Maximum Width Limit (m)	Maximum Length Limit (m)
D1	2,75	27
D2	3,00	30
D3	3,25	34
D4	3,75	40
D5	4,75	54
D6	>4,75	>54

1.5.3 Mass Classification

The mass classification is based on the laden mass.

Table 1.2: Classification According to Mass

Class	Maximum Mass Limit (t)
M1	60
M2	65
M3	80
M4	100
M5	125
M6	>125

1.6 Categories of Routes

1.6.1 Background

Large, wide and slow moving vehicles create increased friction in the traffic streams on the roads that they use. On two-lane undivided roads this affects traffic in both directions, as passing manoeuvres require adequate decision sight distance to be safely carried out. This effect is reduced on multi-lane facilities, especially dual carriageway roads, but it is important to note that the width of the combination is the primary determining factor the amount of disturbance which it causes in the traffic stream. There is therefore a need to relate the width of a load to the width of the road being used in order to estimate the traffic impedance. The design speed of the road also needs to be considered as this is indicative of passing opportunities.

Sections of road are therefore classified in terms of two parameters that are a function of the design standards. These parameters are the paved width and the posted speed limit. A speed limit of 100 km/h or more would ensure adequate sight distance for safe overtaking of abnormal load vehicles on two-way roads.

1.6.2 Route Classification

Using the two parameters of paved width and posted speed limit, road sections are categorised as presented in Table 1.3.

Table 1.3: Route Classification

Category	Paved Width	Posted Speed Limit
A	paved width \geq 18 m	all
B	13 m \leq paved width < 18 m	\geq 100 km/h
C	13 m \leq paved width < 18 m	< 100 km/h
	10 m \leq paved width < 13 m	\geq 100 km/h
D	10 m \leq paved width < 13 m	< 100 km/h
	paved width < 10 m	all

2. DIMENSIONAL LIMITATIONS

2.1 Background

Loads with abnormal dimensions can cause obstruction and danger to other road users. Permits will only be considered for abnormally dimensioned loads that are considered to be indivisible. Table 2.1 summarizes the **legal limits** for different vehicle types.

Table 2.1: Maximum Overall Legal Dimensions (GVM/GCM exceeds 12 t)

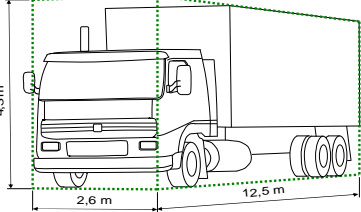
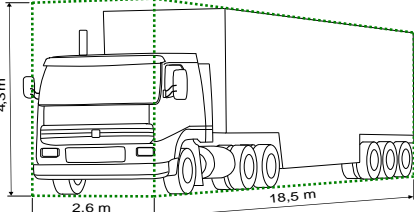
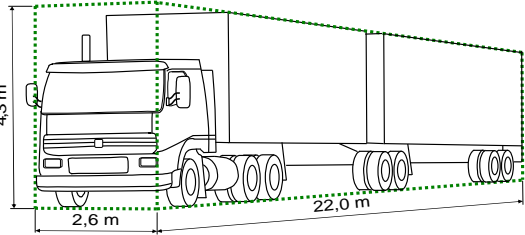
Vehicle Type	Overall Length (m)	Overall Width (m)	Overall Height (m)	Example
Single vehicle (Rigid)	12.5	2.6	4.3	
Articulated vehicle	18.5	2.6	4.3	
Other combinations of vehicles	22.0	2.6	4.3	

2.2 Length

2.2.1 Legally Permissible

Regulation 221 sets the legal limits for the permissible maximum length of road vehicles as shown in Table 2.2.

Table 2.2: Maximum Overall Legal Length (including load projections)

Vehicle Type	Overall Length (m)	Comments
Single vehicle	12.5	Excluding a semi-trailer
Articulated vehicle	18.5	Truck-tractor & semi-trailer
Other combinations of vehicles	22.0	Interlinks, multiple trailers.

2.2.2 Allowable under Permit

Table 2.3 Maximum Overall Length per Vehicle Type (including load projections)

Vehicle Type	Overall Length (m)	Comments
Rigid vehicles	20	Including mobile cranes
Foundation diggers	23	
Articulated vehicles	26	Truck-tractor & semi-trailer
Combinations of vehicles	28	Truck, dolly & semi-trailer

Where abnormally long vehicles could have difficulty in travelling around the sharp curves on some roads, particularly in mountain passes, in urban areas, on freeway ramps, over certain roads with short vertical curves and some bridges, it is necessary to limit further the allowable overall length of the abnormal vehicle.

For the transportation of long loads of up to 20,0 m in length, vehicles of a conventional type without steerable rear axles, or vehicles incorporating non-steerable dollies or extendible trailers may be used. In the case of non-steerable axle units, the longitudinal distance between the extreme axle centres of any axle unit may not exceed 4,2 m.

For the transportation of loads from 20,0 m to 25,0 m in length or for wheelbases exceeding 14,5 m, steerable rear axles or steerable dollies must be used.

For loads longer than 25,0 m all rear axle units must be fully steerable. Alternatively, a steerable dolly with a turntable capable of 180 degree rotation may be used. With this type of vehicle, a rear projection of the load is not desirable and loads should be supported near the end.

Abnormally long loads should be transported by vehicles specifically designed for the conveyance of such loads. Exceptions may be made at the discretion of the MEC in small centres where such vehicles are not available. On the other hand, an abnormally long vehicle may not be used to transport a load which does not require a vehicle of such length.

2.3 Width

2.3.1 Legally Permissible

Regulation 223 stipulates that goods vehicles with a gross vehicle mass of 12 000 kg or more may operate on a public road with an overall width of not more than 2,6 m. All other vehicles shall not exceed 2,5 m in width.

Regulation 230 stipulates that the overall width of certain agricultural and road construction machines shall not exceed 4,5 m and 3,5 m respectively if operated on a public road.

2.3.2 Allowable under Permit

Limits depend on factors such as topography, road width, traffic volumes and obstructions. Special provision must be made in terms of markings and escorting (see Chapter 4: Marking and Escorting) if the vehicle width exceeds 3,5 m.

2.4 Height

2.4.1 Legally Permissible

Regulation 224 sets a limit of 4,3 m on the overall height of a road vehicle, together with its load, measured from ground level.

2.4.2 Allowable under Permit

The principal factors limiting the permissible height of abnormal loads are the clearances under any overhead bridges or overhead lines on the route, and the stability of the vehicle and the load. It is the responsibility of the carrier to identify a suitable route and to substantiate the suitability of the route with the application.

Table 2.4: Actions Required when Transporting High Loads

Height	Action
> 4,3 m	The clearance of every overhead obstruction must be established by the carrier before the vehicle passes under it. (Note that the clearance under a transmission line is not simply the clearance between the conductor and the ground, but that a safety factor should be allowed for, depending on the voltage).
> 4,7 m	A vehicle shall be provided to drive ahead of the abnormal vehicle. A gauge of non-conducting material shall be fitted to the top of this vehicle. The height of the gauge shall be 100 mm higher than the highest point of the abnormal vehicle or load. It is also required of the carrier to give a written confirmation that he knows the particular route and has recently gone through it and should any structural damage occur he will then be held responsible for any financial implications that have resulted.
> 5,5 m	Permission must be obtained from Telkom prior to applying for a permit, unless a lower limit is specified by Telkom for a specific area or route.
> 5,8 m	Permission must be obtained from Eskom prior to applying for a permit, unless a lower limit is specified by Eskom for a specific area or route.

2.5 Overhangs

The front and rear overhangs of a vehicle are illustrated in Figure 2.1.

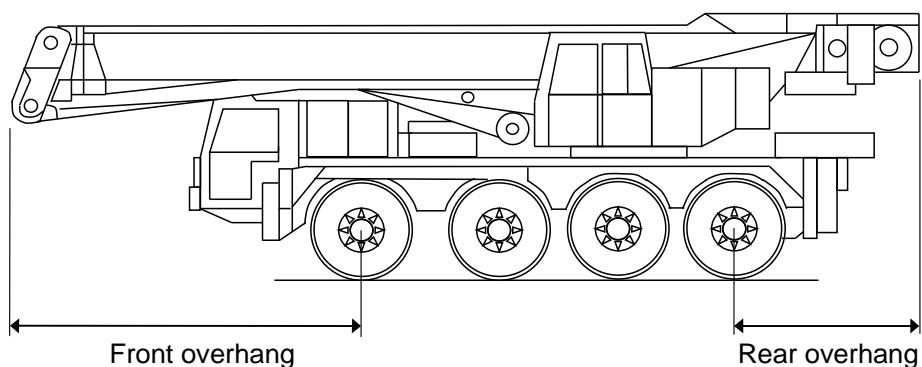

Figure 2.1: Front and Rear Overhangs

2.5.1 Front Overhang

(a) Legally Permissible

Regulation 226 limits the front overhang of a vehicle as follows:

- i) For vehicles where the distance from the front end of the vehicle to the backrest of the driver's seat at seat-level is less than 1,7 m, to the lesser of –

60 per cent of the wheelbase, or
6,2 m less half the wheelbase.
- ii) Where this distance is more than 1,7 m, to the lesser of –

60 per cent of the wheelbase, or
5,8 m less half the wheelbase.
- iii) To 1,8 m for a semi-trailer.

(b) Allowable under Permit

Load carrying abnormal vehicles must comply with the requirements of Regulation 226. For non-load carrying vehicles, refer to section 2.5.3.

2.5.2 Rear Overhang

(a) Legally Permissible

Regulation 226 limits the rear overhang of goods vehicles, measured from the rearmost axle, to 60 per cent of the wheelbase.

(b) Allowable under Permit

The rear overhang of a load carrying abnormal vehicle, measured from the rearmost axle, may not exceed 2 m or 70 per cent of the wheelbase, whichever is the greater, subject to the restriction on load projection stipulated in section 2.6. For non-load carrying vehicles, refer to section 2.5.3.

2.5.3 Front and Rear Overhangs Allowable under Permit for Non-load Carrying Vehicles

In the case of non-load carrying vehicles, such as mobile cranes and foundation diggers, the actual front or rear overhang shall not exceed the values given in Table 2.5. The overhang is measured from the centre of the foremost or rearmost axle to the furthest point of the overhang section of the vehicle.

Table 2.5: Allowable Front/Rear Overhang under Permit for Non-load Carrying Vehicles.

Wheelbase (m)	3 m	4 m	5 m	6 m or more
Allowable front or rear overhang*	3.9	4.6	5.2	6.0

* From the centre of the front or rear axle to the furthest point of the overhang section of the vehicle.

The above-mentioned overhang values may be increased by 50% if the increased overhang section is at a height not less than **2,5 m** above the road surface. In the case of special vehicles such as mobile cranes and drilling rigs, the front overhang of the furthest point of the central unit (the boom) must always be within the outer minimum turning circle of the vehicle.

2.6 Load Projections

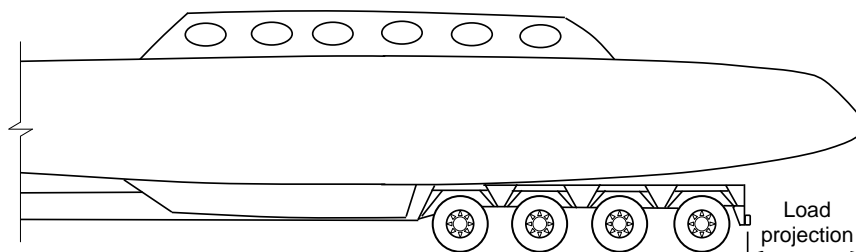

Figure 2.2: Load Projections

2.6.1 Front Load Projection

(a) Legally Permissible

Regulation 227 limits the load projection to **300 mm** beyond the front end of the vehicle.

(b) Allowable under Permit

No abnormal load shall project more than **1,0 m** beyond the front end of the drawing vehicle.

2.6.2 Rear Load Projection

(a) Legally Permissible

Regulation 229 states that a load projecting more than 300 mm beyond the rear end of a vehicle shall be suitably indicated with warning devices and Regulation 227 states that no load shall project more than **1,8 m** and that the combined length of the load and the vehicle shall not exceed the limits presented in section 2.2.1 of this document.

(b) Allowable under Permit

- (i) Vehicles with a rear overhang of more than 50 per cent of the wheelbase: rear projection of the load may not exceed **0,5 m**.
- (ii) Vehicles with a rear overhang of less than 50 per cent of the wheelbase : rear projection of the load measured (a) behind the centre of the rearmost axle unit, and (b) behind the rear end of the vehicle, may not exceed the values given in Table 2.6.

Table 2.6: Allowable Rear Load Projections

Wheelbase (m)	Beyond centre of rearmost axle unit (a)	Beyond rear end of vehicle (b)
3	3,9	2,6
4	4,6	2,9
5	5,2	3,2
6	6,0	3,5

Wheelbase (m)	Beyond centre of rearmost axle unit (a)	Beyond rear end of vehicle (b)
7	6,0	3,7
8	6,0	4,0
9	6,0	4,3
10 and more	6,0	4,5

Where the height of the load above the road surface is not less than 2,5 m, the projection may be increased by 20 per cent or 750 mm whichever is the lesser.

A rear own escort should be provided where the projection exceeds 1,8 m.

2.7 Wheelbase

2.7.1 Legally Permissible

Regulation 225 limits the wheelbase of

- i) semi-trailers to 10,0 m;
- ii) all other vehicles (except bus-trains) to 8,5 m; and
- iii) bus-trains to 15,0 m.

2.7.2 Allowable under Permit

No wheelbase shall exceed 14,5 m unless steerable rear axles or steerable dollies are used.

2.8 Turning Radius

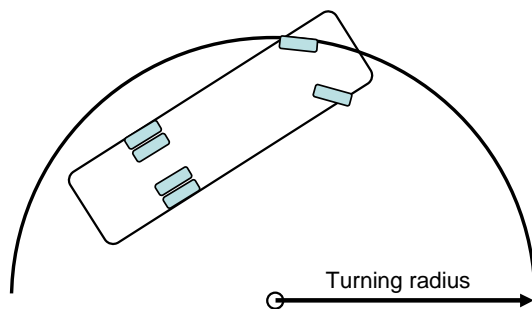

Figure 2.3: Illustration of Turning Radius

2.8.1 Legally Permissible

In terms of Regulation 225 the turning radius of any vehicle shall not exceed 13,1 m except for bus-trains and twin steer 4-axle rigid goods vehicles, where the turning radius shall not exceed 17,5 m.

2.8.2 Allowable under Permit

The maximum turning radii of vehicles will be determined by the geometry of the routes along which these vehicles travel. Traffic officer escort(s) may be required in cases where both the width and turning radius of a vehicle are excessive.

2.9 Stability

In the case of a loaded vehicle with a height/wheel track ratio greater than 2 or a load width/wheel track ratio greater than 1,8, or a load that is asymmetrically loaded, the carrier may be required to produce calculations performed by a professional engineer showing that the loaded vehicle is adequately stable under all conditions of road travel.

Table 2.7: Triggering Values for Stability Checks

Stability Ratio	Triggering Value
Height/wheel track	2,0
Load width/wheel track	1,8

2.10 Ground Clearance

A vehicle or combination must have a ground clearance of not less than 150 mm under laden mass conditions. Trailers with less than 150 mm ground clearance must be able to lift to 150 mm when required to negotiate an undulation in the road surface.

3. MASS LIMITATIONS

3.1 Background

The permissible maximum vehicle or combination mass of a road vehicle or combination of road vehicles that is allowed to operate either legally or under permit on a public road is limited by:

- The capacity of the vehicles as rated by the manufacturer;
- The load which may be carried by the tyres;
- The damaging effect on road pavements;
- The structural capacity of bridges and culverts;
- The power of the prime mover(s);
- The load imposed on the driving axles; and
- The load imposed on the steering axles.

In this section the legal limits permitted by the NRTR are presented, as well as the corresponding limits allowable under permit. In both cases, the lowest allowable mass determines the permissible maximum masses which may be carried legally or under permit respectively.

3.2 Loads on Tyres

Overloading of tyres may lead to tyre failure and may cause an accident endangering and delaying other road users.

3.2.1 Legally Permissible

Regulation 238 stipulates that the limitations on the massload of wheels, as laid down in the South African National Standard SANS 1550 and Recommended Practice ARP 007, shall apply, or if SANS 1550 or ARP 007 do not contain the relevant tyre data, then the design capacity as specified by the manufacturer must be adhered to.

3.2.2 Allowable under Permit

For vehicles operating under permit, the allowable loads given in SANS 1550 and ARP 007 or by the manufacturer must not be exceeded. The speed restrictions must be rigidly adhered to and the wheels and rims must be of adequate strength.

3.3 Manufacturer's Ratings

Manufacturer's rating refers to the maximum massload for an axle or axle unit or the maximum mass of a vehicle or combination of vehicles as specified by the manufacturer. The manufacturer's ratings are referred to as "gross", namely the gross vehicle mass (GVM), gross combination mass (GCM), gross axle massload (GA) and gross axle unit massload (GAU). This information must be clearly imprinted or stamped on the information plate, which in terms of Regulation 245 of the NRTR is required to be affixed to, inter alia, goods vehicle with a GVM exceeding 3 500 kg

3.3.1 Legally Permissible

Regulation 239 stipulates that the gross vehicle mass; gross combination mass; any gross axle massload; or any gross axle unit massload, shall not be exceeded.

3.3.2 Allowable under Permit

No permit will be granted if any of the manufacturer's ratings are exceeded.

3.4 Massload Carrying Capacity of Roads

Every wheel of a vehicle causes some structural damage (wear) to the road pavement. The total damage to a road pavement caused by a vehicle is determined by the tyre pressure, magnitude of the individual wheel loads and the spacing between the wheels. The closer the spacing of the wheels the greater the resultant stresses in the road pavement. The concept of the equivalent single wheel massload (ESWM) deals with this effect (see Section 6.2).

3.4.1 Legally Permissible

Regulation 240 stipulates that axle mass loads shall not exceed those given in Figure 3.1.

Steering Axles	 7 700kg	 15 400kg	 23 100kg
Non-steering Axles	 8 000kg	 16 000kg	 24 000kg
Axles with Dual Wheels	 9 000kg	 18 000kg	 24 000kg

Figure 3.1: Maximum Legal Loads on Axles and Axle Groups

3.4.2 Allowable under Permit

The maximum axle load allowable under permit will depend on the manufacturer's rating for the axle or axle unit and the other vehicle components such as tyres, 5th wheels and kingpins.

An ESWM of up to 6 500 kg may be allowed. Special consideration can be given to non-load carrying vehicles that exceed the limit of 6 500 kg, provided that the axle loads of the non-load carrying vehicle are limited to 12 000 kg per axle. Non-load carrying vehicles refer to vehicles such as mobile cranes and foundation diggers.

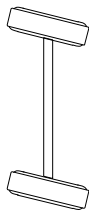
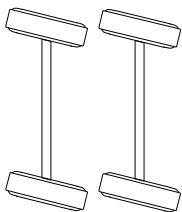
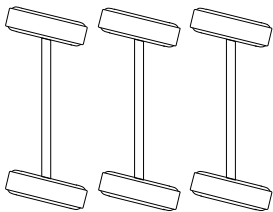
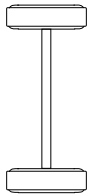
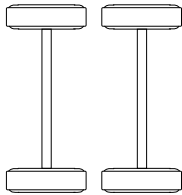
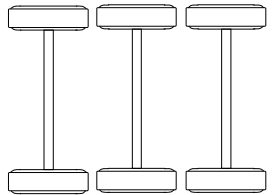
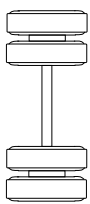
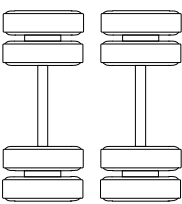
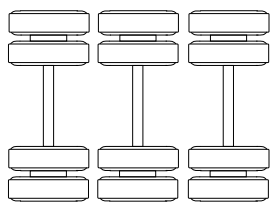
3.5 Massload Carrying Capacity of Bridges and Culverts

The load carrying capacity of bridges and culverts requires that the load intensity of a vehicle be limited. The load carrying capacity of a bridge or culvert is determined by the design and present condition of the structure. The load intensity of a vehicle is determined by the loads on axles and axle units and the spacing of those axles and axle units. It is therefore necessary to limit the load that is carried by a group of axles or axle units.

3.5.1 Legally Permissible

Regulation 241 states that the total axle massload of any group of axles on a vehicle or combination of vehicles may not exceed the mass in kilogram calculated using the following formula:

$$P = 18\,000 + 2\,100 \times L$$

Where: P = Permissible Maximum Mass of the group of axles (in kg); and
L = Distance between the centre of the first axle of any group of axles to the centre of the last axle of such group, measured in metres (rounded up to the next highest tenth of a metre).

3.5.2 Allowable under Permit

In order to check whether an abnormal vehicle may be permitted to cross bridges and culverts en route, it is necessary to calculate the maximum stresses that the abnormal vehicle with its load will cause to be exerted on the various components of the bridges and culverts and then to compare these with the maximum stresses for which the bridges and culverts were designed.

Accurate calculations are complicated, laborious, time consuming and will normally not be required for vehicles, or combinations of vehicles, when the laden mass of the vehicle and/or combination of vehicles does not exceed 125 000 kg, provided the route is specified by the carrier.

For vehicles or combinations of vehicles with a total mass of less than 125 000 kg, any group of axles may not exceed the values given in Table 3.1. The limitations imposed by bridges and culverts on multi axle groups are based on the following formula:

$$M_{AL} = EW \times (6,850 + 0,00145 \times AD)$$

Where: M_{AL} = Allowable maximum mass of the group of axles (in kg);
EW = Effective Width in mm; and
AD = Distance between the centre of the first axle of any group of axles to the centre of the last axle of such group, measured in millimetres.

In addition, unless specifically stated in the permit, no vehicle travelling under an abnormal load permit shall cross any bridge if the total mass or any axle mass load exceeds the maximum permitted for that bridge by an appropriate road traffic sign.

It is the responsibility of the carrier to ensure that the load can safely be carried by all bridges and other structures at the time of the proposed journey. Proof will be required that a recent investigation had been undertaken for the load or a similar or greater load.

3.5.3 Distances between Axle Groups

Whenever the spacing between the **last** axle of the leading group and the **first** axle of the trailing group of two groups of axles is less than 5 m, the axles must be considered as one group when applying the load limitations of Table 3.1. For multiple trailer/semi-trailer combinations, where the spacing between the last axle of the leading trailer/semi-trailer and the first axle of the following trailer/semi-trailer is less than 7 m, the allowable axle loads in Table 3.1 shall be reduced by 10 per cent per 1 m reduction of this distance with a lower limitation of 5 m, below which the axles must be considered as one group. Hauler-trailer combinations of gross mass exceeding 125 000 kg require special investigation.

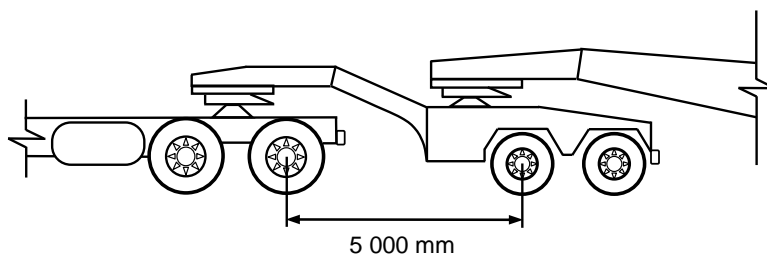

Figure 3.2: Distances between Axle Groups

3.5.4 Tracking Requirements

When determining the maximum allowable load, consideration must be given to other traffic that may be present on a bridge. Moreover, very heavy load combinations should travel along a path which minimises overstressing, usually the centreline of the bridge.

Vehicles or combinations of vehicles, in which the allowable axle group loading exceeds the value in the extreme right hand column of the applicable line of Table 3.1, shall proceed so that the centre of the load shall not be more than 1,0 m from the centre line of a bridge with an overall length exceeding 60 m. In such cases, the structure will be temporarily closed to all other road users. This condition must be clearly stated as a permit condition by the Issuing Authority. It requires the services of at least two traffic officer escorts to control other traffic.

Table 3.1: Limitations on the Maximum Allowable Mass (in kg) of Multi Axle Groups imposed by Bridges and Culverts

Distance between extreme axles (m)	Effective width (m)													Tracking required
	3,5	3,6	3,7	3,8	3,9	4,0	4,1	4,2	4,3	4,4	4,5	4,6	4,7	
1,2	30070	30920	31780	32640	33500	34360	35220	36080	36940	37800	38660	39510	40370	30950
1,5	31590	32490	33390	34300	35200	36100	37000	37910	38810	39710	40610	41520	42420	33700
1,8	33110	34060	35000	35950	36890	37840	38790	39730	40680	41620	42570	43520	44460	36300
2,1	34630	35620	36610	37600	38590	39580	40570	41560	42550	43540	44530	45520	46510	38750
2,4	36160	37190	38220	39250	40290	41320	42350	43390	44420	45450	46490	47520	48550	41300
2,7	37680	38750	39830	40910	41980	43060	44140	45210	46290	47370	48440	49520	50600	43100
3,0	39200	40320	41440	42560	43680	44800	45920	47040	48160	49280	50400	51520	52640	45100
3,3	40720	41890	43050	44210	45380	46540	47700	48870	50030	51190	52360	53520	54680	46900
3,6	42250	43450	44660	45870	47070	48280	49490	50690	51900	53110	54320	55520	56730	48550
3,9	43770	45020	46270	47520	48770	50020	51270	52520	53770	55020	56270	57520	58770	50050
4,2	45290	46580	47880	49170	50470	51760	53050	54350	55640	56940	58230	59520	60820	51800
4,5	46810	48150	49490	50830	52160	53500	54840	56180	57510	58850	60190	61530	62860	52600
4,8	48340	49720	51100	52480	53860	55240	56620	58000	59380	60760	62150	63530	64910	53600
5,1	49860	51280	52710	54130	55560	56980	58400	59830	61250	62680	64100	65530	66950	54500
5,4	51380	52850	54320	55780	57250	58720	60190	61660	63120	64590	66060	67530	69000	55200
5,7	52900	54410	55930	57440	58950	60460	61970	63480	64990	66510	68020	69530	71040	55800
6,0	54430	55980	57540	59090	60650	62200	63760	65310	66870	68420	69980	71530	73090	56200

- i) Values are based on the formula: **Allowable Mass (kg) = EW x (6,850 + 0,00145 x distance between extreme axles)** where EW, the effective width, and the distance between extreme axles are in mm (values are rounded to the nearest 10 kg).
- ii) **Interpolation is permitted but not extrapolation.**
- iii) Where loads exceed the maximum unrestricted values given in the last column, vehicles will be subject to special tracking requirements and structures will be temporarily closed to other road users. This applies to all values to the right of the heavy stepped line in the table.

3.6 Limitations Imposed by Drawing Vehicles (Power to Mass Ratio)

It is important that legally loaded as well as abnormally loaded vehicles be adequately powered so that a reasonable travel speed can be maintained to avoid unnecessary traffic congestion.

3.6.1 Legally Permissible

Regulation 239 requires that the mass in kilograms of a vehicle or combination of vehicles does not exceed a figure arrived at by multiplying the net power in kW of the engine of such vehicle as determined in accordance with or calculated with due regard to Code of Practice "SANS 10013-1 - The Determination of Performance (at net power) of Internal Combustion Engines":

- i) in the case of the drawing vehicle being a tractor, by 400,
- ii) in the case of any other vehicle, by 240.

3.6.2 Allowable under Permit

- i) For abnormal vehicles and/or combination of vehicles with a total mass of less than 23 000 kg, the provisions of Section 3.6.1 will apply.
- ii) For abnormal vehicles and/or combination of vehicles with a total mass exceeding 23 000 kg, the net power in kW of the engine(s) of such vehicle, as determined in accordance with or calculated with due regard to Code of Practice SANS 10013-1, shall not be less than the value calculated using the following formula:

$$P = (50 \times n) + \left(\frac{CM}{500} \right)$$

Where: P = Required net power in kW of the engine of the vehicle;
n = Number of drawing vehicles in the combination; and
CM = Total mass in kg of the combination of vehicles

except that in the case of mobile cranes and other similar specialised self-propelled vehicles, the permissible maximum vehicle mass shall not exceed a figure arrived at by multiplying the net power in kW of the engine of such vehicle as determined in accordance with or calculated with due regard to Code of Practice SANS 10013-1, by 300.

- iii) When two or more drawing vehicles are used to pull an abnormal load, each drawing vehicle must have a GCM rating of at least 54 000 kg and an engine power of at least 220 kW and the drawing vehicles must be compatible in performance.

3.7 Massload on Drive Axles (Traction Ratio)

To ensure sufficient traction, a minimum ratio of massload on the drive axles to total vehicle/combination mass is specified.

3.7.1 Legally Permissible

Regulation 239 states that the massload carried on the drive axles shall not be less than 20 per cent of the total mass of the vehicle and/or combination of vehicles.

3.7.2 Allowable under Permit

The massload carried on the drive axles shall not be less than 20 per cent of the total mass of the vehicle and/or combination of vehicles, except for drawing vehicles pulling drawbar trailers in easy, level country on dry roads, when 15 per cent may be considered. In all other cases, 20 per cent will also be required for the latter type of vehicle.

3.8 Massload on Steering Axles (Steering Ratio)

To ensure steerability, minimum standards of loads on steering axles are laid down in Regulation 242.

3.8.1 Legally Permissible

Regulation 242 states that:

- i) In the case of a combination of motor vehicles consisting of a truck tractor and at least one semi-trailer, the axle mass load of any steering axle or the sum of the axle mass loads of any steering axle unit may not be less than 11 per cent of the sum of all axle mass loads of the truck tractor and the first semi-trailer that is coupled to the truck tractor;
- ii) In the case of a motor vehicle, not being a combination of motor vehicles as referred to in paragraph (i), with a steering axle unit, the sum of the axle mass loads of such steering axle unit may not be less than 30 per cent of the sum of all axle mass loads of such vehicle; or
- iii) In the case of any other vehicle, the axle massload of a steering axle is less than 20 per cent of the sum of all axle massloads of such vehicle, except in the case of an agricultural tractor when the axle massload of the steering axle shall not be less than 12 per cent of the sum of all the axle massloads of such tractor.

3.8.2 Allowable under Permit

The massload carried on the steering axle(s) shall not be less than 15 per cent of the total mass of the drawing vehicle(s).

4. MARKING AND ESCORTING

4.1 Introduction

It is possible to transport wide and long loads safely, provided they are adequately marked with warning devices and/or escorted. The warning devices and escorts that are required will depend on the length, width, height and overhang of the abnormal load or vehicle.

4.2 Description of Warning Apparatus

4.2.1 Flags

The extremities of the vehicle or load must be identified by a display of bright red flags to indicate the overall length and width of the vehicle or load. Each flag must be securely attached to the load or to a staff on the vehicle. The flags must be placed at the extreme corners of the vehicle or load, must measure at least 600 mm x 600 mm, must be clean and free to flutter.

4.2.2 Boards

(a) Abnormal Vehicle Warning Board

An abnormal vehicle warning board must be displayed at the front and the rear ends of the abnormal vehicle, except in the case of mobile cranes, where an abnormal vehicle warning board must be displayed at the rear only. The abnormal vehicle warning board must be at least 2 000 mm wide and 300 mm high. The background of the warning face of the board must be white. The warning face must bear the word "ABNORMAL" in red retro-reflective letters of the modified series E letters, at least 200 mm high. The material used in the manufacturing of the board must comply with the relevant requirements as specified in South African National Standard SANS 1329 "Retro-reflective and fluorescent warning signs for road vehicles, Part 2: Abnormal load vehicle signs".

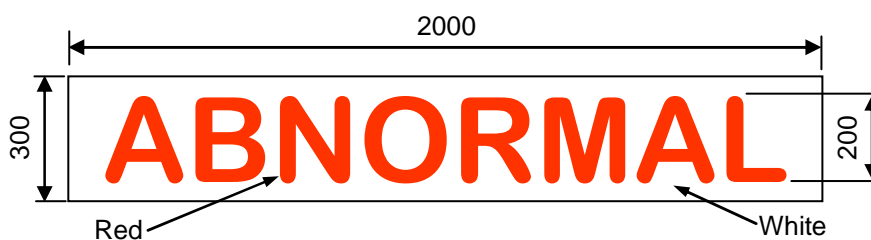

Figure 4.1: Abnormal Vehicle Warning Board

(b) Escort Vehicle Warning Board

A warning board with two warning faces must be fitted to the roof of the escort vehicle. The warning board must be at least 1 200 mm long by 400 mm high. The background of the warning faces of the board must be white. The warning faces must bear the words "ABNORMAL LOAD AHEAD" in retro-reflective red modified series E letters, at least 120 mm high. The material used in the manufacturing of the board must comply with the relevant requirements as specified in South African National Standard SANS 1329 "Retro-reflective and fluorescent warning signs for road vehicles, Part 2: Abnormal load vehicle signs".

The warning board must be removable, collapsible or coverable and must not obscure the amber flashing lights referred to in section 4.2.3(a).

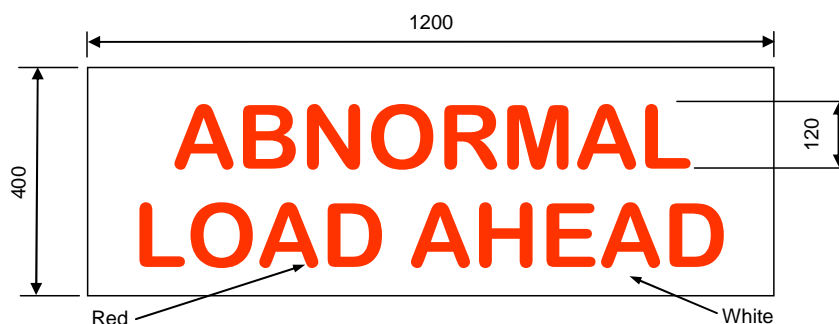

Figure 4.2: Escort Vehicle Warning Board

(c) Speed Restriction Board

When a speed restriction board is required (see Section 4.3.4), it must be fitted above the warning board at the rear of the vehicle indicating the maximum speed allowable. Such sign shall comply with the requirements for a type H sign as specified in South African National Standard SANS 1329 "Retro-reflective and fluorescent warning signs for road vehicles", Part 3: "Signs other than triangles, chevron signs and abnormal load vehicle signs".

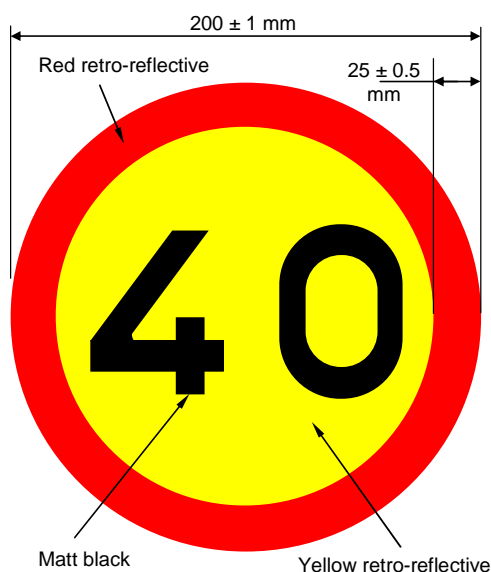

Figure 4.3: Speed Restriction Board

4.2.3 Lights

(a) Amber Flashing Lights

An amber flashing light shall be fitted on top of the cab of the hauling vehicle, or on top of the cab of the front hauling vehicle if there are more than one hauling vehicle, as well as on top of the escort vehicle(s). In the case of a mobile crane, an amber flashing light must be fitted to the foremost end of the front overhang so as to be visible from all sides, and a second amber flashing light must be fitted to the rear of the mobile crane. The front light may be fitted to the cab for daylight operations only. The visibility distance of the amber flashing lights shall be 150 m as specified in Regulation 158(2) of the NRTR.

(b) Marker Lamps and Retro-reflectors

When required, the extremities of length and width of abnormal loads/vehicles must be indicated by marker lamps and retro-reflectors. Front-facing lamps must be green and retro-reflectors must be white. Rear-facing lamps and retro-reflectors must be red and side-facing lamps and retro-reflectors must be amber. The marker lamps and retro-reflectors referred to are in addition to the lamps and retro-reflectors specified in Chapter VI Part II of the NRTR.

4.3 Warning Apparatus Requirements

The Abnormal Vehicle Warning Board described in Section 4.2.2(a) shall be required for all abnormal loads.

4.3.1 Long and Wide Loads

The warning apparatus requirements for abnormally long and wide loads can be determined with the aid of Figure 4.4 or can be read from Table 4.1, using the calculated Road Usage Factor (RUF) value. The formula to calculate the RUF is presented in Section 7.3.

Table 4.1: Warning Apparatus Requirements for Long and Wide Loads

RUF Limit	Warning Apparatus Required	See also
RUF < 0,54	Flags	4.2.1
	Abnormal vehicle warning board	4.2.2(a)
RUF >= 0,54	Flags	4.2.1
	Abnormal vehicle warning board	4.2.2(a)
	Amber Flashing Lights	4.2.3(a)
	Marker lamps and retro-reflectors	4.2.3(b)

4.3.2 Projections

Regulation 229 stipulates that projections beyond the legal limits must be indicated with warning flags. For loads that project more than 1,8 m beyond the rear of the vehicle, flags must be fitted to each side of the load, at the end of the projection.

4.3.3 Night Travel

The provisions of Section 4.2.3(b) will be enforced when the abnormal load is allowed to travel during times when lights are required. During unfavourable weather conditions the vehicle must either comply with Section 4.2.3(b) or the driver must pull the vehicle off the road.

4.3.4 Speed Restrictions

Any abnormal vehicle/load which is limited to a speed of 60 km/h or less when travelling on public roads must be fitted with a speed restriction sign prescribed in Section 4.2.2(c).

4.3.5 Warning Apparatus Prohibited

When abnormal vehicles and escort vehicles are not operating under a permit requiring the use of warning boards and flags, such apparatus may not be displayed. Flashing and other lights must be extinguished.

4.4 Escorting of Abnormal Vehicles

4.4.1 Background

An abnormal vehicle is accompanied by escort vehicles to warn the normal travelling public of the abnormal vehicle and to promote a safer flow of traffic in the face of possible disruption caused by the abnormal vehicle.

Unless specifically authorised, a private escort has no legal authority to control other traffic. However, when it is necessary for a private escort to control other traffic, it shall always be done in a reasonable manner, bearing in mind that the safety and convenience of other road users shall always enjoy precedence over that of the abnormal vehicle.

4.4.2 Escort Classes

(a) Own Escort

An own escort is an escort vehicle that is provided by the carrier, which should be a passenger motor car or a light motor vehicle as defined in the NRTA with a GVM not exceeding 3 500 kg. The escort vehicle must be equipped with an amber flashing light and an abnormal vehicle warning board on the roof of the vehicle, positioned such that it is visible from all directions.

Where a single own escort vehicle is specified, the escort vehicle must travel between 10 m and 50 m behind the abnormal vehicle, as far back as possible within sight of it, to give other road users timely warning of the presence of the abnormal vehicle, but allowing normal overtaking when conditions allow. When the abnormality is caused by an excessive front overhang or when a height gauge is prescribed for loads exceeding 4,7 m, the escorting vehicle must travel in front of the abnormal vehicle.

Where two own escort vehicles are specified, the one vehicle must travel in front and the other vehicle behind the abnormal vehicle, travelling between 10 m and 50 m from the abnormal vehicle.

(b) Traffic Officer Escort

Traffic officer escorts are provided by the road traffic authorities and will normally consist of two vehicles. In some cases, one traffic officer escort vehicle may be replaced by an own escort vehicle at the discretion of the permit office.

4.4.3 Escort Requirements

(a) Width and Length

The class and number of escorts required are a function of both the length and the width of the loaded vehicle. The requirements for escorts, in terms of the dimension class (see Table 1.1) and route category (see Table 1.3), are presented in Table 4.2.

Table 4.2: Escort Requirements for Wide and Long Loads in terms of Dimension Class and Route Category

Dimension Class	Route Category			
	A	B	C	D

Dimension Class	Route Category			
	A	B	C	D
D1	No escort	No escort	No escort	No escort
D2	No escort	No escort	No escort	One own escort vehicle
D3	No escort	No escort	One own escort vehicle	Two own escort vehicles
D4	No escort	One own escort vehicle	Two own escort vehicles	Two traffic officer escort vehicles
D5	One own escort vehicle	Two own escort vehicles	Two traffic officer escort vehicles	Two traffic officer escort vehicles
D6	Two traffic officer escort vehicles	Two traffic officer escort vehicles	Two traffic officer escort vehicles	Two traffic officer escort vehicles

In the absence of a route category, the escort requirements can be determined with the aid of Figure 4.4, or can be read from Table 4.3, using the calculated Road Usage Factor (RUF) value. The formula to calculate the RUF is presented in Section 7.3.

Table 4.3: Escort Requirements for Wide and Long Loads in terms of the RUF

RUF Range	Escort Requirements
$RUF \leq 0,54$	No escort required.
$0,54 < RUF \leq 0,94$	One own escort vehicle required.
$0,94 < RUF \leq 2,73$	Two own escort vehicles required.
$RUF > 2,73$	Two traffic officer escort vehicles or one traffic officer escort vehicle and one own escort vehicle.

An additional municipal escort vehicle may be required by local authorities in urban areas. Other factors such as topography, road width, traffic volume and tracking requirements over bridges, may also influence escort requirements and Figure 4.4 should be used as a guide.

Under exceptional circumstances two or more traffic officer escort vehicles may be required in addition to two own escort vehicles, at the discretion of the issuing authority. On dual carriageway roads, one or more of the traffic officer escort vehicles may be dispensed with at the discretion of the issuing authority.

(b) Height

For any vehicle exceeding 4,7 m in height, an own-escort vehicle is required to drive between 10 m and 50 m ahead of the abnormal vehicle (see Section 2.4.2: Table 2.4). A traffic officer escort vehicle may be required where the lifting of overhead lines or other arrangements may require the abnormal vehicle(s) to stop in the roadway.

(c) Overhangs

Where the front overhang of a mobile crane or foundation digger exceeds either of the following, one own escort vehicle must be provided:

- Overhang exceeds 4,5 m measured from the front surface of the backrest of the driver's seat; or

- Overhang exceeds 6,5 m measured from the centre of the front axle.

Where the front overhang exceeds 8 m, a traffic officer escort vehicle may, at the discretion of the Issuing Authority, be required in addition to the own escort.

(d) Load Projections

Where the rear load projection exceeds 1,8 m, one own escort vehicle must be provided to travel behind the load.

(e) Mass

When tracking over bridges is required in terms of Table 3.1, at least one traffic officer escort vehicle is required.

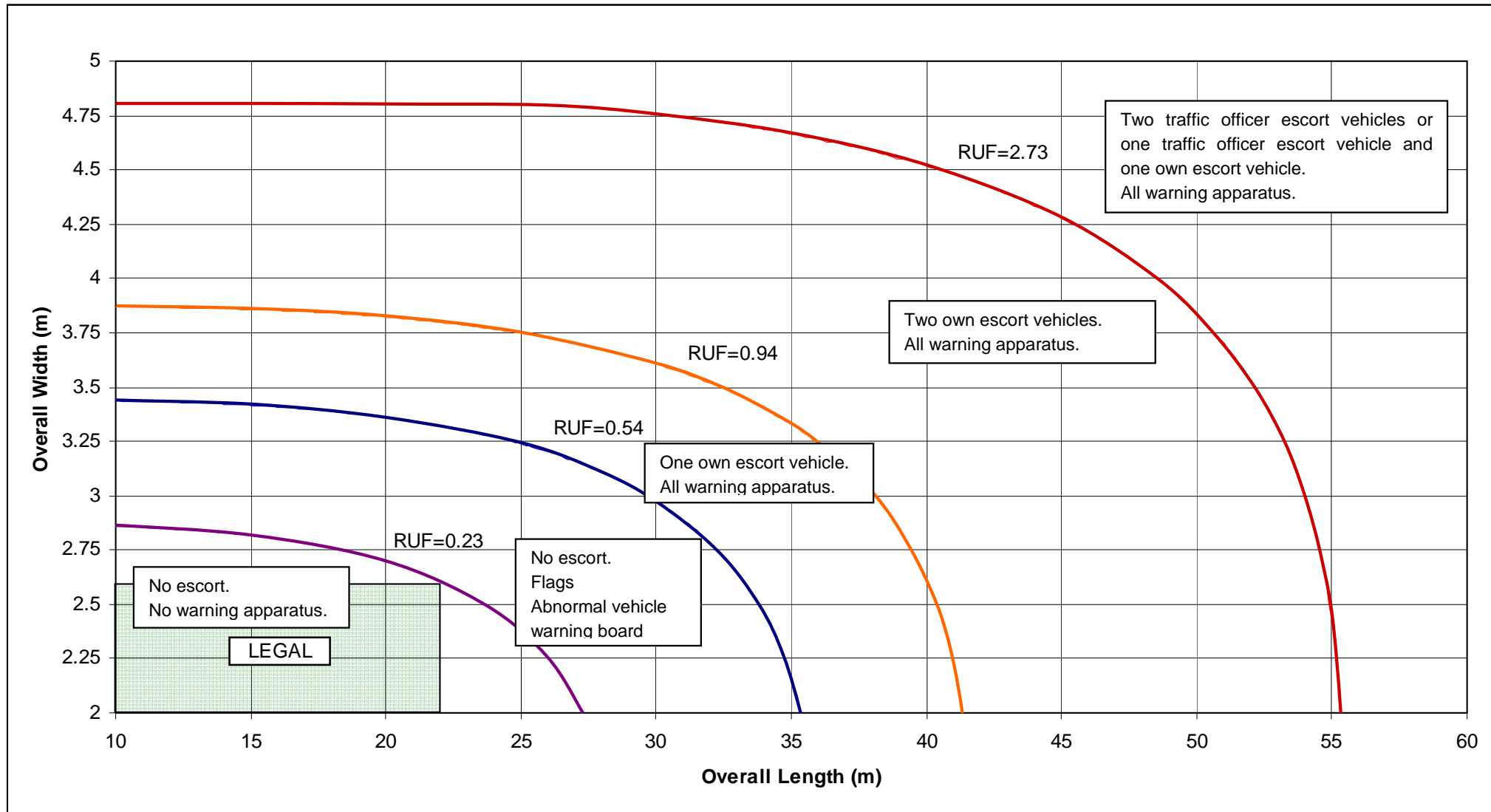

Figure 4.4: Warning Apparatus and Escort Requirements

5. SPEED RESTRICTIONS

5.1 Background

The maximum speed at which an abnormal vehicle is permitted to travel on public roads is dependent on factors such as the load on the tyres, the load on bridges and the dimensions of the loaded vehicle.

5.2 Tyre Loading

It may become necessary to restrict the speed of an abnormally heavy vehicle to enable heavier loads to be carried safely on tyres. These restricted speeds are given in Table 5.1.

Table 5.1: Speed Restrictions due to Tyre Loading

Ratio $\frac{a - b}{a - c}$	Maximum speed (km/h)
0,00 - 0,07	30
0,08 - 0,21	40
0,22 - 0,36	50
0,37 - 0,50	60
0,51 - 0,64	70
0,65 - 1,00	80

Where:
a = maximum combination mass allowable under permit
b = actual combination mass for which permit is issued
c = legal permissible maximum combination mass

Table 5.1 is based on the ETRTO Standards Manual, a normative reference in SANS 1550-1: Part 1 Motor vehicle tyres and rims — Dimensions and loads, which allow tyre loading capacity to be increased if the vehicle speed is limited to 30 km/h. For legally loaded vehicles no special speed restrictions are required and for intermediate loads intermediate speeds on a proportional basis may be permitted.

5.3 Bridge Loading

For abnormally heavy vehicles, lower speeds are required over bridges in order to reduce the magnitude of the impact forces. These maximum speeds are given in Table 5.2.

Table 5.2: Maximum Allowable Speeds over Bridges

Total combination mass (kg)	Maximum allowable speed over bridge (km/h)
Not exceeding 50 000	80
60 000	70
70 000	60
80 000	50
90 000	40
100 000	30

Total combination mass (kg)		Maximum allowable speed over bridge (km/h)
	110 000	20
	250 000	10
Exceeding	250 000	5

(The maximum allowable speed over bridges will be as per Table 5.2, unless otherwise stipulated on the abnormal vehicle registration certificate or permit.)

5.4 Dimensions

For vehicles that are dimensionally excessive, the maximum speed is related to the escort requirements, as given in Table 5.3.

Table 5.3: Maximum Allowable Speeds for Vehicles or Loads of Abnormal Dimensions

Permit conditions	Maximum allowable speed, km/h	
	Rural	Urban
No warning apparatus or escort required	80	50
Warning apparatus required but no escorts	70	40
One own escort vehicle	60	40
Two own escort vehicles	50	30
Traffic officer escort vehicle(s)	To be decided by escorting officer but not more than:	
	60	40

Where vehicles or loads are both abnormally heavy and abnormally dimensioned, the lowest of the values given in Table 5.1, Table 5.2 and Table 5.3 must be used.

5.5 Mobile Cranes

The maximum speed for mobile cranes in both rural and urban areas is given in Table 5.4.

Table 5.4: Maximum Allowable Speeds for Mobile Cranes

Type of Mobile Crane	Maximum Speed (km/h)
Cranes mounted on truck type chassis and all terrain cranes	60
Centre mounted cranes	20

6. ESTIMATION OF RELATIVE ROAD PAVEMENT DAMAGE BY ABNORMAL VEHICLES

6.1 Introduction

One of the fundamental principles guiding the process of issuing exemption permits for the transport of abnormal loads is that the damage to the road infrastructure by an abnormal vehicle has to be recovered from the carrier.

To recover the damage done to road pavements by abnormal vehicles, a mass fee in R/km is calculated and then multiplied by the distance to be travelled by the abnormal vehicle to determine an amount payable.

To determine a mass fee, three steps are required in general:

- Step 1: Convert the various arrangements of wheels and axles into a measure that allows a rational comparison of these arrangements;
- Step 2: Determine the relative damage caused by a particular arrangement of wheels and axles as compared to some standard; and
- Step 3: Determine the cost of such damage

Various methods can be used to convert the various arrangements of wheels and axles into a measure that allows a rational comparison of these arrangements and to determine the relative damage caused by a particular arrangement of wheels and axles as compared to some standard.

One method is based on the well-known Equivalent Standard Axle concept, which is described in TRH 16: 1991 Traffic Loading for Pavement and Rehabilitation Design. Two other methods are the Equivalent Single Wheel Mass (ESWM) method and a method based on the South African mechanistic-empirical pavement design methodology (SAMDM).

6.2 Equivalent Single Wheel Mass (ESWM) Method

The ESWM of a group of wheel loads is that load on a single standard wheel load that induces the same critical stress and/or deflections in the road pavement as that induced by the group of wheel loads. The basis for this calculation in South Africa was established by Van Vuuren in 1972 (Reference 7). This principle was reviewed in 1994 and implemented in the Sixth Revision of TRH 11 (September 1997). The review incorporated some of the mechanistic-empirical (M-E) approaches for road pavement design. A description of this method and the formulas used can be found in Reference 8 and Reference 9.

6.3 South African Mechanistic-empirical Pavement Design Methodology (SAMDM)

This approach involves the use of the SAMDM methodology to estimate the Load Equivalency Factors (LEFs) of each vehicle under static loading, based on the critical pavement layer life approach. The philosophy of "Equivalent Pavement Response - Equivalent Pavement Damage" (EPR-EPD) is used instead of reducing an abnormal vehicle to a single ESWM, or to an equivalent Standard Axle Load (Reference 10).

With the EPR-EPD approach, no “fixed equivalencies” are used per se, and each vehicle is considered with its full axle/tyre configuration (i.e. tyre/axle loading and its associated tyre inflation pressure) as input into the SAMDM and the road damage (or “additional pavement damage”) of the abnormal vehicle is directly estimated for the pavement type under consideration. With the EPR-EPD approach the stresses and strains (i.e. mechanistic pavement response parameters) are directly related through the associated transfer functions (TF) for pavement damage to layer life and hence “pavement life”. With this approach, the pavement life is considered as being equal to the “critical layer life”, i.e. the life of the structural layer with the lowest life in the pavement structure.

The “pavement life” under each axle of the vehicle is calculated, summed and compared relative to the bearing capacity of the pavement in terms of the Standard 80 kN/520 kPa axle with four tyres (two dual sets) at a tyre inflation pressure of 520 kPa.

The Total Damage of the vehicle (TD_v) is calculated as the sum of the ratios (for all axles of a particular vehicle) between the critical layer life of the pavement determined from the Standard 80 kN/520 kPa axle with four tyres (two dual sets) at an inflation pressure of 520 kPa (i.e. the bearing capacity of the pavement), divided by the critical layer life under each individual axle load and its associated tyre pressures. This TD_v is taken as the LEF.

The Mass Fee/km in ZAR is then equal to $TD_v \times R$, where R = the average cost estimate of one “Standard Axle-lane-km” of road in SA in ZAR.

The pavement life is calculated using the mePADS software of the SAMDM. The basic mechanistic-empirical methodology is freely available within South Africa from the CSIR Built Environment (mePADS, 2008) - see website: <http://asphalt.csir.co.za/samdm/>.

More information is available in Reference 10.

7. TECHNICAL DETAIL AND CALCULATIONS

7.1 Introduction

This section contains reference material to some of the technical details and calculations used in the document.

7.2 Detailed Glossary

7.2.1 5th Wheel

A device fitted to a truck-tractor, adapter or converter dolly in order to permit articulation between the said unit and a semi-trailer.

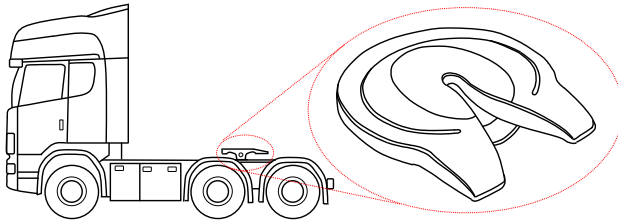

Figure 7.1: 5th Wheel on Truck Tractor

7.2.2 Axle Configurations

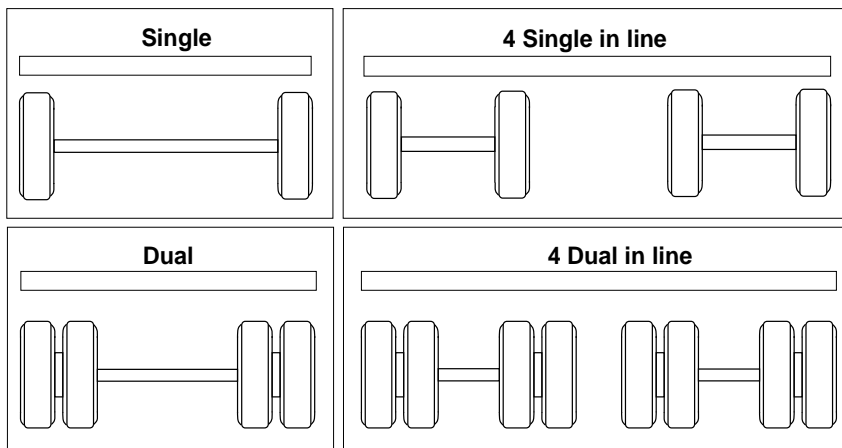

Figure 7.2: Common Axle Configurations on Abnormal Vehicles

7.2.3 Legal Axle Loads

Steering Axles	 7 700kg	 15 400kg	 23 100kg
Non-steering Axles	 8 000kg	 16 000kg	 24 000kg
Axles with Dual Wheels	 9 000kg	 18 000kg	 24 000kg

Figure 7.3: Legal Axle Loads in terms of Regulation 240 of the NRTR

7.3 Road Usage Factor (RUF) Calculation

$$\text{Road usage factor RUF} = 1,61757 \times 10^{-3} \times W^{4.7} + 7,5 \times 10^{-7} \times L^{3.76}$$

Where: W = overall load / vehicle width, m
L = overall combination length, m

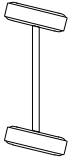
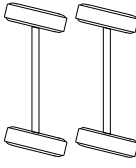
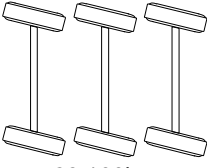
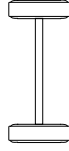
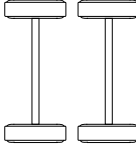
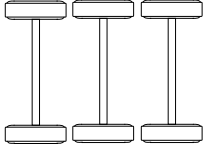
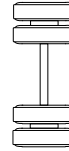
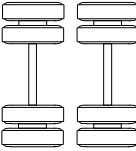
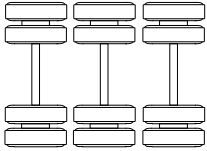
Table 7-1: Examples of RUF Calculations

Width (m)	Length (m)	RUF	Comment
2,60	22,0	0,23	Max legal width and length
2,75	27,3	0,38	Category D1
3,00	30,4	0,56	Category D2
3,25	33,6	0,82	Category D3
3,75	40,2	1,61	Category D4
4,75	54,0	4,90	Category D5

7.4 Effective Width Calculation

7.4.1 Effective Width of a Single Axle or Single Axle Group

The massload of any wheel is assumed to be distributed over the width of the tyre (W) plus 600 mm on each side. Any overlap from adjacent wheels is subtracted from the effective width. Where wheels are spaced less or equal to 1 200 mm + W on an axle, the effective width is the width to the outside of the outer tyres plus 1 200 mm. If any spacing exceeds 1 200 mm + W, the excess is deducted from the effective width.

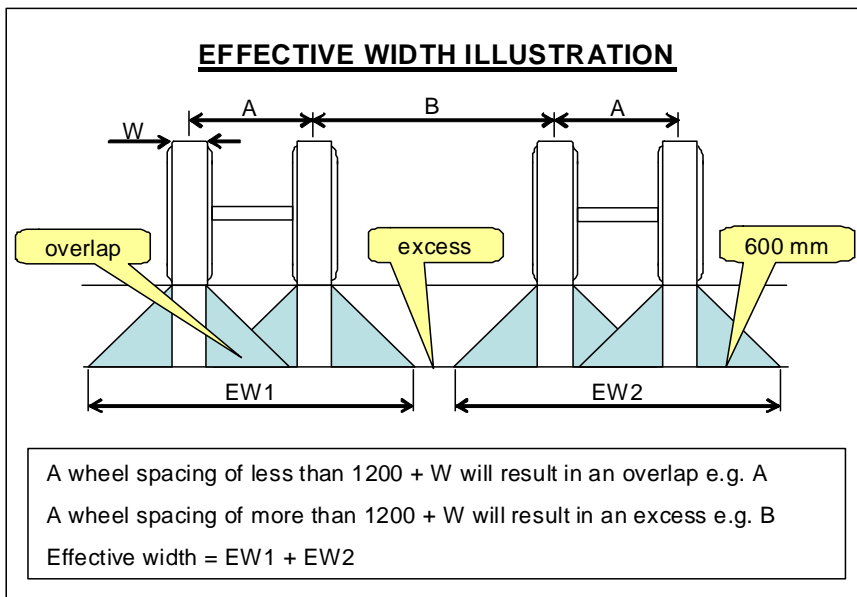

Figure 7.4: Illustration of Effective Width Calculation

7.4.2 Weighted Effective Width Calculation

Whenever the spacing between the **last** axle of the leading group and the **first** axle of the trailing group of two groups of axles is less than 5 m (see Figure 3.2), the axles must be considered as one group. The effective width of each group is calculated and a 'weighted' effective width is determined as follows:

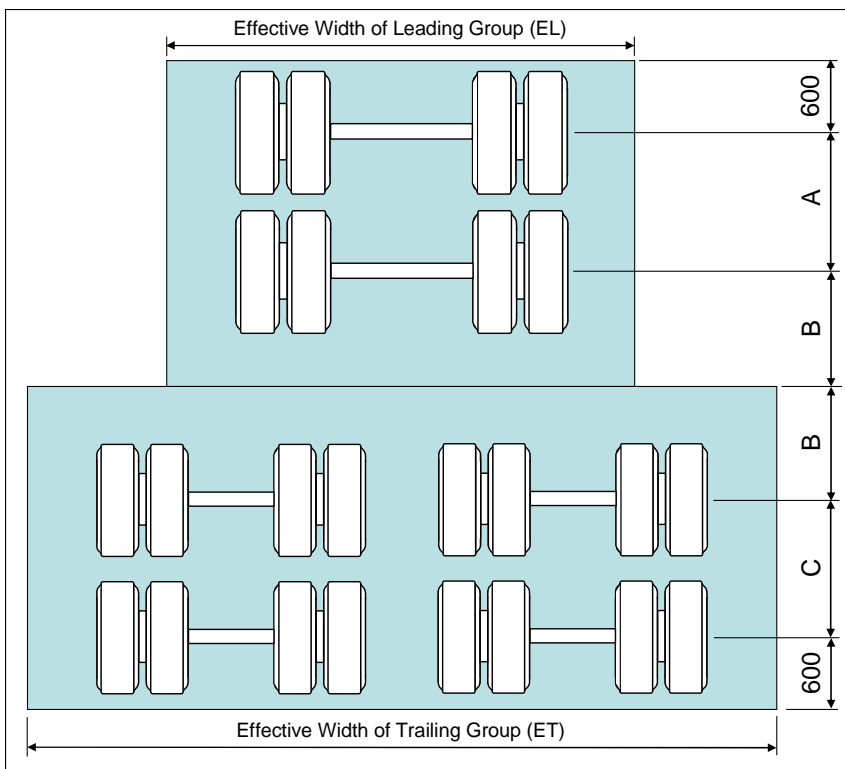

Figure 7.5: Example of 'Weighted' Effective Width Calculation

- Calculate **B** as half the distance between the **last** axle of the leading group and the **first** axle of the trailing group (mm).
- Calculate the area of the leading group (AL):

$$AL = EL * (B + A + 600)$$

Where:

EL ≡ Effective Width of leading group (mm)

A ≡ Distance from first to last axle in the leading group (mm)

- Calculate the area of the trailing group (AT):

$$AT = ET * (B + C + 600)$$

Where:

ET ≡ Effective Width of trailing group (mm)

C ≡ Distance from first to last axle in the trailing group (mm)

- Calculate the weight of the leading group (WL):

$$WL = AL * \text{Number of wheels in the leading group}$$

- Calculate the weight of the trailing group (WT):

$$WT = AT * \text{Number of wheels in the trailing group}$$

- Calculate the weighted effective width (WE) in mm:

$$WE = \frac{(WL * EL) + (WT * ET)}{(WL + WT)}$$

7.5 Tyre Pressure Calculation

- Determine the number of single (S) or dual (D) axle fittings in the axle unit e.g. a unit consisting of 4 axles fitted with 4-duals in line has 8 dual axle fittings.
- Divide the total mass of the unit by the number of axle fittings to obtain the load per individual axle fitting.
- Adjust the load per individual axle by the percentage variation in load capacity with speed from Table 7.2 e.g. at 30 km/h a 25 per cent increase in load capacity is applicable means the actual load can be reduced by 25 per cent (divide by 1.25).

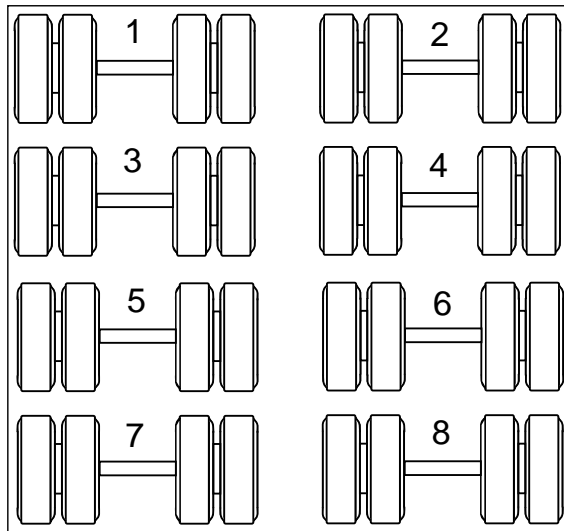

Figure 7.6: 4-Axle unit with 4-Duals in-line

Table 7.2: Variation in Load Capacity with Speed*

Speed km/h	Variations in Load Carrying Capacity with Speed (%)						Pressure Compensation (%)
	F 80 km/h	G 90 km/h	J 100 km/h	K 110 km/h	L 120 km/h	M 130 km/h	
Static	See column J	See column J	+150	See column J	See column J	See column J	+40
5			+110				+40
10			+80				+30
15			+65				+25
20			+50				+21
25			+35				+17
30			+25				+13
35			+19				+11
40			+15				+10
45			+13				+9
50			+12				+8
55			+11				+7
60			+10				+6
65			+7.5				+4
70			+5				+2
75			+2.5				+1
80			0				+4
85		+2	+3	0			
90		0	+2	0			
95			+1	0			
100			0	0			
105				0	0	0	
110				0	0	0	
115					0	0	0
120					0	0	0
125						0	0
130						0	0

*Source: European Tire and Rim Technical Organization – Standards Manual

- Using the applicable load/pressure table for the requested tyre, find the applicable load or interpolate between two columns of load values to determine the appropriate pressure to carry the load.
- Adjust the pressure with the 'pressure compensation percentage' from Table 7.2 e.g. 13 per cent for a speed of 30 km/h.

Table 7.3: Example of a Load at Pressure Table

Tyre Size: 315/80 R 22.5												
Load Index / Speed / Fitment			Load capacity (kg) per axle at tyre pressure (kPa)									
			450	500	550	600	650	700	750	800	850	900
154	M	S	4510	4905	5295	5675	6050	6420	6785	7145	7500	
150		D	8055	8765	9460	10140	10810	11470	12125	12765	13400	

8. REFERENCES

1. National Road Traffic Act, Act 93 of 1996.
2. National Road Traffic Regulations, 2000.
3. SANS 1550: Motor vehicle tyres and rims - Dimensions and loads.
4. SANS 1329-2: Retro-reflective and fluorescent warning signs for road vehicles - Part 2: Abnormal load vehicle signs.
5. SANS 1329-3: Retro-reflective and fluorescent warning signs for road vehicles - Part 3: Signs other than triangles, chevron signs and abnormal load vehicle signs.
6. SABS Recommended Practice ARP 007: The care, maintenance and use of motor vehicle tyres and rims (incorporating TREDCO guidelines)
7. Van Vuuren, D.J., (1974). Tyre pressure and its effects on Pavement Design and performance. National Institute for Road Research (NIRR), Council for Scientific and Industrial Research (CSIR). Report RR 192, Pretoria, South Africa.
8. Report 80286 (1994). Final Report on the Development of a new Policy and Structure for Abnormal Permit Fees. RSA, Committee of State Road Authorities, Report by Van Wyk & Louw Inc., for the Deputy-Director General: Roads, Natal Provincial Administration, Pietermaritzburg, KwaZulu Natal, South Africa, January, 1994.
9. Supplementary Report 80286 (1994). Supplementary Report: Review of Abnormal Mass Load Fees. RSA, Committee of State Road Authorities, Report by Van Wyk & Louw Inc., for the Deputy-Director General: Roads, Natal Provincial Administration, Pietermaritzburg, KwaZulu Natal, South Africa, February, 1994.
10. De Beer, M., Sallie I. and Van Rensburg, Y. (2008). Revision of TRH 11 (1999-2000): Recovery of Road Damage - Discussion Document on a Provisional Basis for Possible New Estimation of Mass Fees - Under Review for TRH 11 (2000). Final Summary V1.0. Contract Report CSIR/BE/IE/ER/2008/0006/B-1, CSIR Built Environment, Pretoria, South Africa, October 2008.

Appendix A: Regulations applicable to Abnormal Loads and Vehicles

Regulation No.	Title
CHAPTER III	
REGISTRATION AND LICENSING OF MOTOR VEHICLES, AND REGISTRATION OF MANUFACTURERS, BUILDERS AND IMPORTERS, AND MANUFACTURERS OF NUMBER PLATES	
Part I	
Registration and licensing of motor vehicles	
21 (1) (h)	Special classification of motor vehicle in relation to motor vehicle licence fees.
CHAPTER VI	
FITNESS OF VEHICLES	
Part II	
Equipment on or in respect of vehicles	
157	Vehicles to be equipped with certain lamps and times when certain lamps to be lighted.
158	Visibility distance of lights
176	Identification lamps
188	Yellow retro-reflectors to be fitted on sides of certain motor vehicles.
189	General requirements for retro-reflectors.
220	Certain vehicles exempt from certain provisions of this Part.
Part III	
Dimensions of vehicles	
221	Overall length of vehicle.
222	Restriction on combination of motor vehicles.
223	Overall width of vehicle.
224	Overall height of vehicle and load.
225	Turning radius and wheelbase.
226	Overhang of vehicle.
227	Projections in case of vehicle other than motor cycle, motor tricycle, motor quadrucycle or pedal cycle.
229	Warning in respect of projecting load.
230	Certain vehicles exempt from provisions of this Part.
Part IV	
Loads on vehicles	
234	Permissible maximum axle massload of vehicle.
235	Permissible maximum axle unit massload of vehicle.
236	Permissible maximum vehicle mass.
237	Permissible maximum combination mass.
238	Load on tyres.
239	Gross vehicle mass, gross axle massload, gross axle unit massload, gross combination mass, power to mass ratio and axle massload of driving axle to total mass ratio not to be exceeded.
240	Massload carrying capacity of road.
241	Massload carrying capacity of bridges.
242	Distribution of axle massload and wheel massload on vehicle fitted with pneumatic tyres.
249	Certain vehicles exempt from provisions of this Part.